

ADSL - Broadband Problems and Solutions



ADSL

ADSL (Asymmetric Digital Subscriber Line) is a service that uses your existing telephone line to provide a broadband service that allows the telephone line and a high-speed internet connection to be used simultaneously.

ADSLF

Unlike existing 2 wire ADSL micro filters, the ADSLF In-Line Micro Filter/Splitter is a four wire device. It connects all four wires used in the Mode 3 connection thus giving an effective Central Filter to all of the Phones connected on return wires (1 and 5) of the Mode 3 connection.

In a Mode 40 connection only terminals 6 and 2 need to be connected to filter the STU. If the ADSLF is installed in front of the phones, all phones will also be filtered from the ADSL signal.

An ADSL in-line micro filter separates the telephone service from the ADSL data. Without ADSL in-line micro filters, you voice calls will receive interference when ADSL is being transmitted. An ADSL in-line micro filter is required between each telephone device and the telephone wall outlet. This includes fax machines, fax/modems, answering machines, cordless phones and alarm diallers.

MCMs ADSLF micro filter/splitter is the ONLY filter tested and approved to work with MCMs Securitel interfaces (STUs) and dialler products.

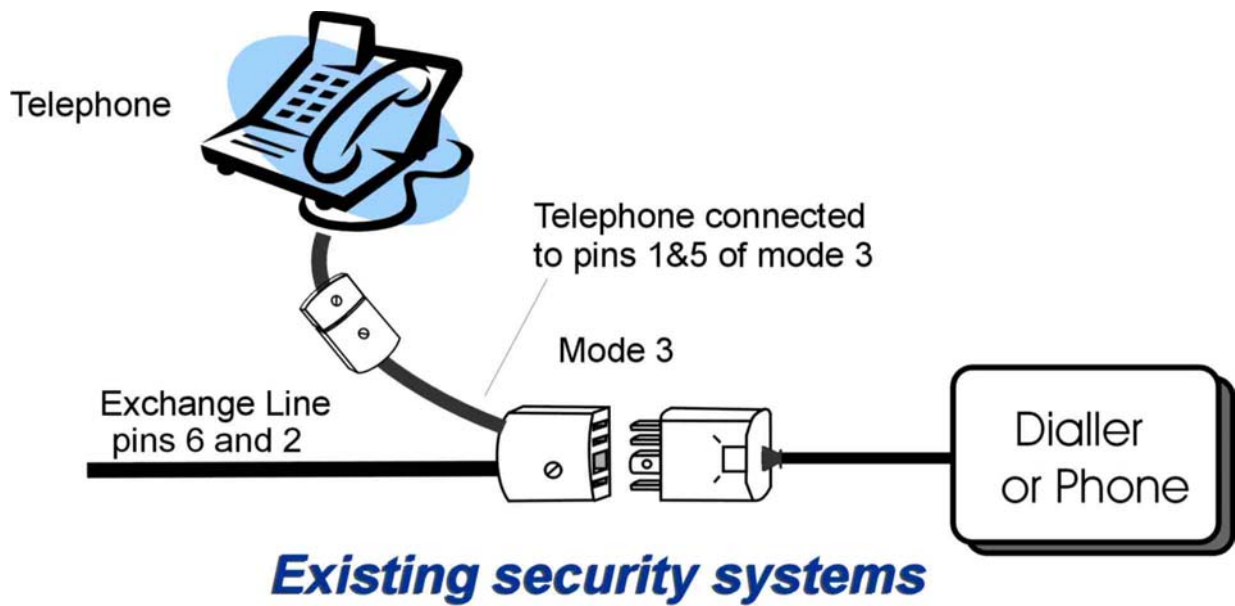

Problems with existing modem/filter combinations

Multiple ADSL filters can be added (one on each phone/device) or a central filter can be used depending on the existing wiring. The limit on the number of older micro filters could be 2 to 3 before they affect (unbalance) the line which would then affect the performance of the ADSL modem.

The range limit of ADSL is approximately 3.6kms from exchange.

ADSL does not operate over pair gains system.

If a "standard" micro filter is used on an alarm system, the filter being only a 2 wire device, does not allow for connection of the 4 wires required for the mode 3 or mode 5. Hence the return connection of the line to the phone is not possible.

With the introduction of "do it yourself installation" there is more chance of incorrect configuration of the ADSL modem/alarm panel/phone combination.

Problems or Symptoms

There have been a number of reported symptoms of the interference caused by the ADSL modem.

- ❖ ADSL connected to a neighbour's phone line causing interference on your phone line.*
- ❖ Diallers failing to send test reports or test reports not being received at the Central Station.*
- ❖ Increased phone bill - dialler continues to dial and doesn't shut down until max attempts reached.*
- ❖ Multiple reports of the same event are being received in the Central Station.*
- ❖ Alarms or Events not being received by the Central Station.*
- ❖ Alarm panel seizing the line and not returning it for long periods.*
- ❖ With no filter Securitel STU would go "NON Responding".*
- ❖ We have not had any reports about adjacent line inference to a STU but it is possible.*

Performance comparisons with other ADSL filters.

Tests of a number of ADSL micro filters have shown that MCM's filter gives a major improvement in the rejection of unwanted signals.

Amended standard from 1st January 2003

MCMs micro filter is the only 4 wire micro filter approved to comply with the stringent new amended standard which was introduced on 1st January 2003.



AS/ACIF S002-2001 including amendment.

ADSL Modem/Router Installation

Unless your ADSL Modem/Router has been supplied with a combined SPLITTER/FILTER, it must be connected directly to the telephone line without an ADSL in-line micro filter. Please refer to instructions supplied with the ADSL Modem/Router and/or your ADSL service provider.

DSL or Broadband is a new modem technology which operates at a higher voltage and a higher frequency levels than older modems. In the range of 10 kHz to 1MHz. This high frequency signalling is used on standard telephone lines because the signal is at a high level and a wide frequency band, the ADSL signal can interfere with the normal phone service unless a filter is installed. This installation between the ADSL modem and the phone (whether it is a phone, dialler, modem, fax or Securitel STU).

ADSLF In-Line Micro Filter/Splitter Installation

For each device that shares the ADSL phone number.

Unplug the devices cord (modular RJ11/RJ45) at the device (alarm panel, fax, answering machine or phone).

Connect the in line micro filters "LINE" socket to the Exchange line.

Using the short telephone cable supplied, connect between the micro filters "PHONE" socket and the alarm panel (or communications divide) as shown below.

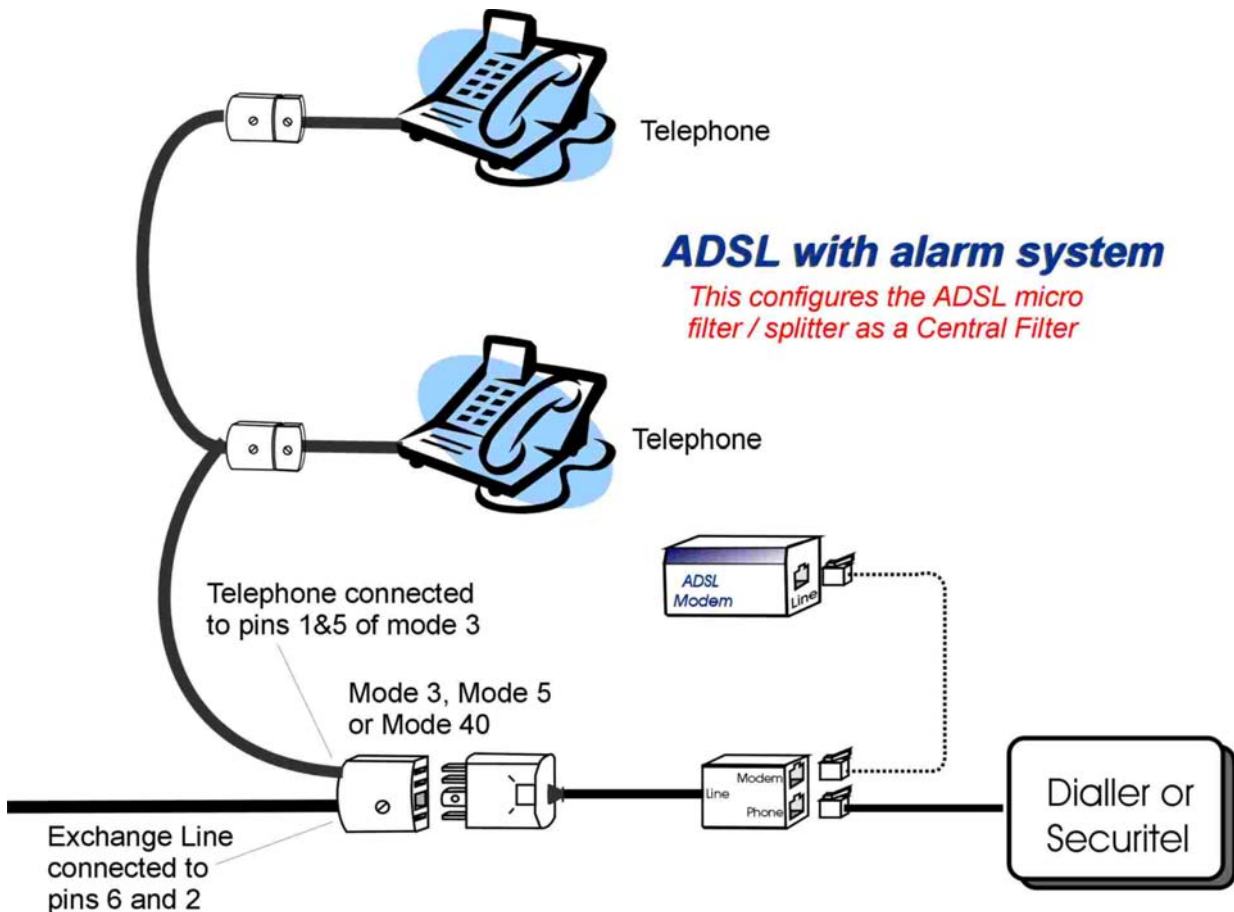

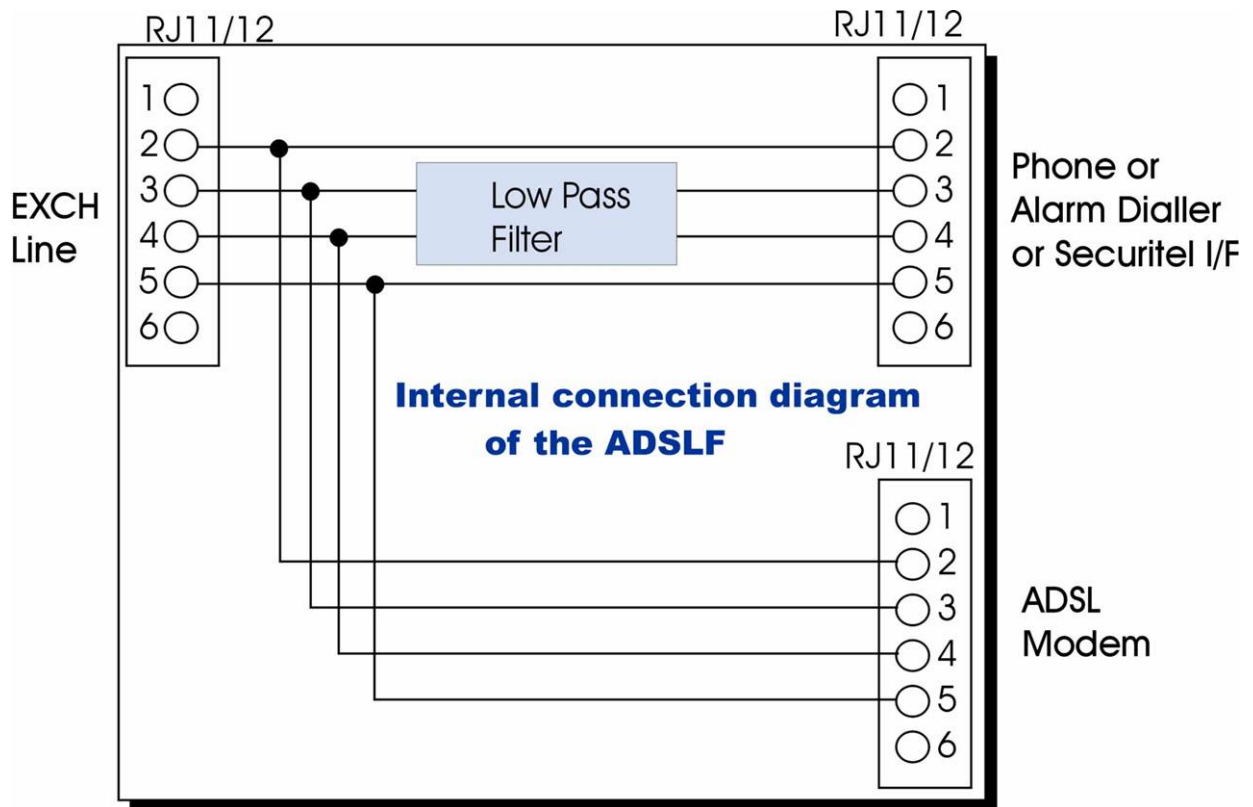

MCMs ADSLF filter splitter - internal connections

MCM Electronics Pty Ltd.
 3/10 Abel Street,
 Penrith NSW 2750
 Phone 02 4721 8067
 Fax 02 4721 8572
 Web site: www.mcmelectronics.com.au
 Email: admin@mcmelectronics.com.au

Written by James Neville - MCM Electronics Pty Ltd.
 © Copyright 2003 MCM Electronics Pty Ltd.