



GSM • PRODUCTS • SOLUTIONS

SED- 62
GSM / GPRS SYSTEM
INSTALLATION & USER
MANUAL
This product is GPRS enabled
via SUREPOLL WIRELESS

WARNING

THIS SECURITY DEVICE MUST BE INSTALLED
BY A QUALIFIED & AUTHORIZED PERSON.
PLEASE READ THIS MANUAL FULLY BEFORE
INSTALLING THIS PRODUCT.

WWW.SECENG.COM.AU

Sydney, Australia

This manual is subject to copyright

Warranty and Liability

WARNING

- 1/ The SED 62 is only to be installed by an authorised service person.
- 2/ The supplied 16VAC Plug Pack must only be connected to a AC 240v outlet socket with a protective earth connection.
- 3/ Ensure that the antenna is covered in 20mm conduit, when installing in exposed places.
- 4/ Ensure the unit is mounted in a safe, secure & **UPRIGHT** position.

The above points should be taken seriously. Failing to abide by the above points, may result in the product not performing as designed.

PRODUCT WARRANTY

This product is covered by a 12 month, **Back-to-Base Warranty**, from the date of purchase, and proof of purchase should be supplied. The warranty does not cover damage that has resulted in the improper installation or use of the product. The warranty does not cover damage by lightning, product misuse, electrical surges or acts of god.

LIMITATION OF LIABILITY

Sec-Eng Systems' products are intended to reduce the risk of loss and damage to property in which the goods are installed to the extent which is practical. Sec-Eng Systems does not accept any liability for the loss or damage to property or persons in relation to goods supplied. This disclaimer is only limited to the warranty of the goods supplied and the intended use of the goods.

TABLE OF CONTENTS

Section 1 - BASIC SETUP

- 1.1 Installation Overview Diagram
- 1.2 SIM Card Installation
- 1.3 Wiring and Terminations
- 1.4 Indication Lights
- 1.5 Operating Modes & Programming

Section 2 - INTELLIGENT SETUP

- 2.1 Manual Programming Mode
- 2.2 SMS Programming Mode
- 2.3 Programming Functions Summary
- 2.4 Program functions 1 6
- 2.5 Program functions 7 11
- 2.6 Program functions 12 16
- 2.7 Program functions 17 25
- 2.8 SMS reports
- 2.9 SMS commands
- 2.10 Control Room report codes
- 2.11 Local dialing

Section 3 - GPRS SET UP

- 3.1 Enabling GPRS
- 3.2 Operational mode in GPRS

Section 4 - TESTING AND HELP

- 4.1 SED 62 Testing and Commissioning
- 4.2 Fault Guide
- 4.3 GPRS Testing
- 4.3 Technical Support

1.1

Installation Overview Diagram

MODEL : SED - 62 GSM SYSTEM BY SEC-ENG SYSTEMS AUSTRALIA

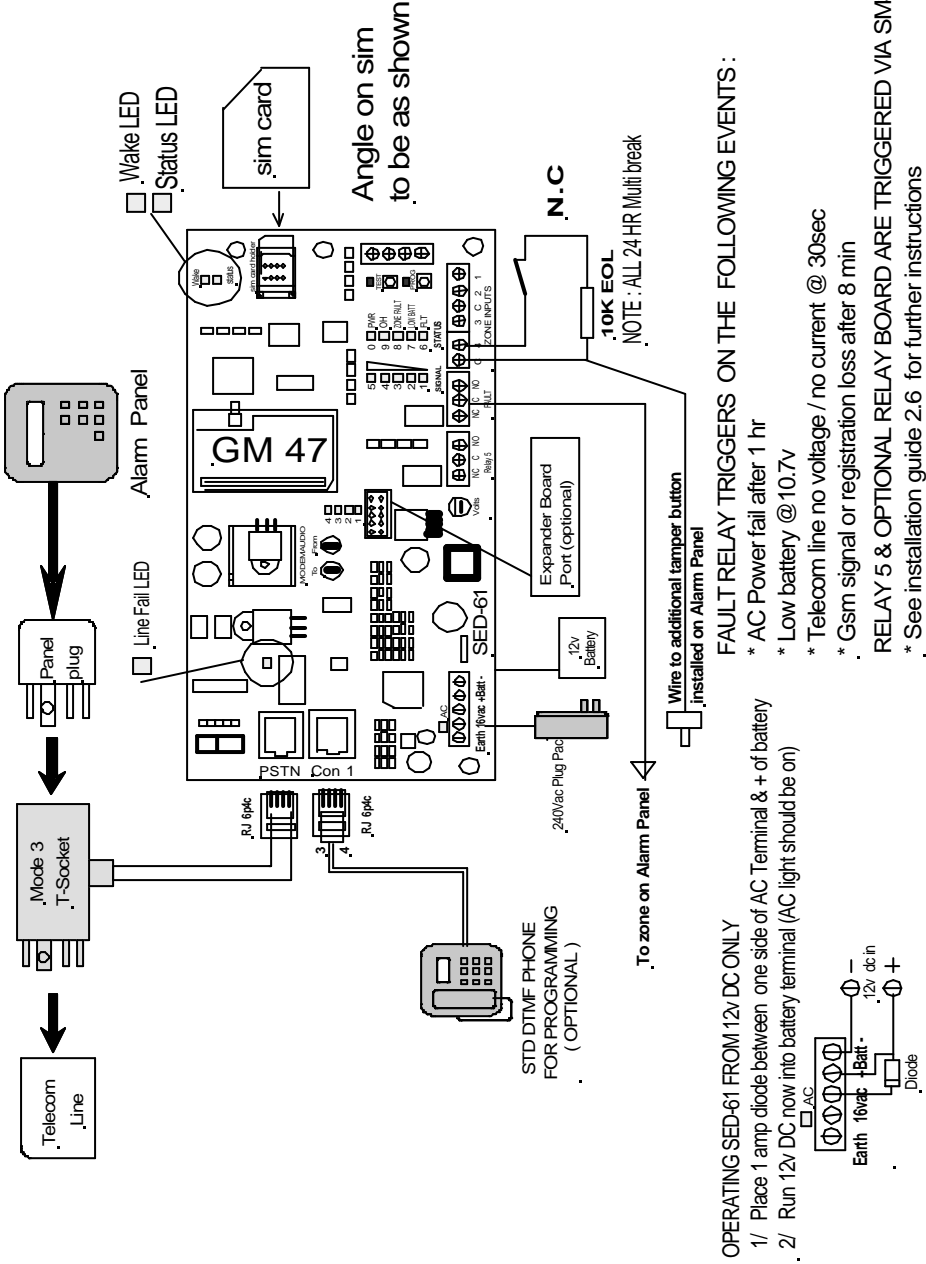

1 Check SIM card Operation in Mobile phone

Place the SIM card into any Standard GSM Phone.

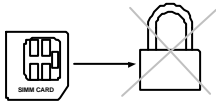

If the phone requests you to enter a pin number then the SIM card is **PIN LOCKED**

NOTE: The SIM card PIN request must be disabled before it can be used in the SED-62



Warning: Ensure you have the correct pin number. Entering the wrong PIN will PUC lock the SIM which will then need to be returned to the vendor for reprogramming.

Disabling the PIN on the SIM card

To disable the PIN go to the mobile phone security menu and select **PIN OFF**

Once done re-test by turning the phone OFF then ON. The pin code should not be requested.

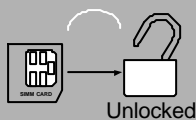

2 Ensure that the SIM Card does work and that a call can be conducted from the Mobile Phone.

3 Test for signal strength (min 3 bars) at the alarm location with the mobile phone.

4 Install the SIM card in the SED-62 as shown in the Installation (Is the sim in the right side up) see 1.1

1.3

Wiring and Terminations

Terminal Connections

Terminal	Description
POWER	
Earth	Connect to mains earth via plug pack Note: remove solder tinning on earth wire, if provided, before connecting.
16 vac	AC input 16v AC plug pack (As supplied with unit only)
16 vac	AC input 16v AC plug pack (As supplied with unit only)
BATT +	12v DC battery input Positive
BATT -	12v DC battery input Negative
RELAY5	(programmable)
NC	normally closed contact
C	common contact
NO	normally open contact
FAULT RELAY	
NC	normally closed contact
C	common contact
NO	normally open contact
	Warning: GSM fault relay is at TNV-3 and is rated 0.5 A at 125 vac
ZONE INPUTS	(24hr Multibreak) 10k E.O. L (MUST BE INSTALLED)
C	Common for Zones Inputs (negative float)
4	10k end of line resistor required to common
3	10k end of line resistor required to common
C	Common for Zone Inputs (negative float)
2	10k end of line resistor required to common
1	10k end of line resistor required to common
PSTN	To Mode 3 T-Socket (to panel and phone line)
CON 1	Used for programming via telephone handset and for audio across GSM
RS 485	Optional RS-485 com port

On board LED Indications

LED	Normal Operation	In Programming mode
1	Signal level Low	Indicates the digit 1
2	Signal level Min	Indicates the digit 2
3	Signal level Med	Indicates the digit 3
4	Signal level Good	Indicates the digit 4
5	Signal level Best	Indicates the digit 5
6 FLT	GSM Fault	Indicates the digit 6
7 BAT	Low battery	Indicates the digit 7
8 ZFLT	Zone unsealed	Indicates the digit 8
9 OH	GSM Transmitting	Indicates the digit 9
0 PWR	Power On	Indicates the digit 0
13 Fault Relay	Fault Relay	
14 Line Fault	Telephone line not detected	
15 AC	AC OK	

Fault LED Guide on Power up

If **LED 6 (FLT)** is flashing refer to the LED's as shown below for the fault indication.

5 <input type="checkbox"/>	0 <input type="checkbox"/> PWR	<input type="checkbox"/>	LED1 ON = Not Applicable
4 <input type="checkbox"/>	9 <input type="checkbox"/> OH	<input type="checkbox"/>	LED2 ON = Not Applicable
3 <input type="checkbox"/>	8 <input type="checkbox"/> ZONE FAULT	<input type="checkbox"/>	LED3 ON = GSM signal or registration fault
2 <input type="checkbox"/>	7 <input type="checkbox"/> LOW BATT	<input type="checkbox"/>	LED4 ON = Not Applicable
1 <input type="checkbox"/>	6 <input type="checkbox"/> FLT	<input type="checkbox"/>	LED5 ON = No SIM card or locked SIM
SIGNAL	STATUS	<input type="checkbox"/>	LED6 ON = GSM fault
		<input type="checkbox"/>	LED8 ON = Zone 1 - 4 unsealed

1.5 Operating Modes & Programming

Operating Modes

1

BASIC GSM BACK UP SYSTEM

Connect the phone line to the male side of the T-socket and the customers alarm panel to the female side ,connect the RJ lead as shown in 1.1 to the Sed 62 Wire the GSM fault relay into a 24Hr zone on the customers alarm panel.

2

INTELLIGENT GSM BACK UP SYSTEM

(WE RECOMMENDED THAT THE INTELLIGENT MODE BE USED IN MOST CASES)

Connect the phone line to the male side of the T-socket and the customers alarm panel to the female side ,connect the RJ lead as shown in 1.1 to the Sed 62 Wire the GSM fault relay into a 24Hr zone on the customers alarm panel. Power up the SED-62 and program functions 1, 2 & 3. For programming details see **Section 2.0 of this manual Ensure the control room has set up the communication Template on 2.10**

3

GSM FULL TIME (IF THERE IS NO PHONE LINE OR WILL NEVER BE INSTALLED)

Program Function 07 for **GSM Full Time** (option = 0) and connect the customers alarm panel to the female side of the T-socket.

(you can also wire the RJ lead from the panel to RJ on the Sed 62 con 1)

4

GPRS SUPERVISED POLLING

Phone 1300 65 44 33 to activate GPRS supervised polling

Programming

There are 2 available methods to program the SED-62:

Manual Mode (Section 2.1)

Plug a standard telephone butt into the SED-62 Port marked "Con 1" and program as per **Section 2.1**

OR

SMS Mode (Section 2.2)

Send a formatted text messages via SMS from any mobile phone to program as per **Section 2.2.**

Manual Programming Mode

2.1

Ensure the unit is powered up and working with no faults. Plug any standard telephone handset (**set to tone dialling**) into the connector marked "Con 1" on the SED-62. Lift the handset and make sure you can hear a digital dial tone.

To enter program mode

Press and hold the **Prog Button**. When the **Prog LED** illuminates followed by **LED 1**, release the program button. **You are now in Program mode 1**

Programming Example

Key into the phone the following:

*019999#

This now has programmed the dialler account code 9999 into function 01

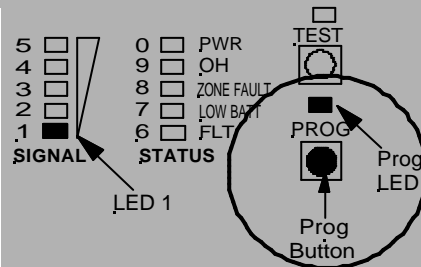

To read function 01 back, key *01# into the phone. LED 9 will flash 4 times indicating that 9999 is programmed in as the account code.

To exit program mode

Press and hold the **Prog Button** until LED 1 goes off, then release the program button. The PROG LED should be off and the other LEDs will return to normal.

SMS Programming Mode

2.2

To program the SED-62 using SMS from any mobile phone, Simply write a text message in the format of * "Function No" "Option No" # and then send it to the SIM card mobile phone number in the SED-62.

Attention : If the Master Code (function 19) has been enabled, you must first send * 19 ???? # (the ???? = Master Code) This will allow SMS Programming Mode access for 5 minutes.

Example to program Function 01 client code = 9999 using SMS

Send the following text message *019999# to the SED-62. To program multiple functions, just separate messages with a comma eg *019999#,*02134673#

Note: All SMS functions must start with a ***(star)** and end with a **#(hash)**. Do not use any spaces in between. This is the same as if you were programming the SED-62 using manual mode programming.

2.3

Programming Functions Summary

Function Number	Function Description	Default
Communications setup		
01	Client code	0000
02	Primary Receiver	nil
03	Secondary Receiver	nil
System Timers		
04	GSM on-board dialer test time	24hrs
05	GSM signal fail relay trigger time	8min
06	PSTN alarm delay	30sec
GSM Communication modes		
07	GSM Back Up / GSM FT / GSM FT PSTN Backup	1
08	PABX mode	0
09	Zones 1-4 lock out control	0
Ademco system reporting codes		
10	Ademco event codes of on-board GSM dialer	0
11	Software Version (Read only)	n/a
SMS set up and control		
12	Mobile phone 1 for SMS alarms	nil
13	Mobile phone 2 for SMS alarms	nil
14	Mobile phone 3 for SMS alarms	nil
15	Report options for SMS messages (general)	0
16	Report options for SMS messages (for zones 1-4)	0
On-board zones set-up		
17	Configuration of zone types	0
18	Confirmation of arming/disarming zones via SMS	0
PIN Code Setup		
19	Master Code	nil
Fault Relay setup		
24	Functions & setting of Fault Relay Control (relay 0)	0
I/O Expander		
25	Enable I/O expander card	0

Function 01- client code

2.4

This sets the account code that the SED-62 will use when using its' on-board dialler to report to the Monitoring Company.

Options:
Any 4 digit number

Example : *019999#

Function 02- Primary receiver number

This sets the primary phone number that the SED-62 will dial when using its' on-board dialler to report to the Monitoring Company.

Options:
Any phone number up to 18 digits

Note: Make sure the phone number can be dialled from a mobile phone

Example : *021234567#

Function 03- Secondary receiver number

This sets the secondary phone number that the SED-62 will dial when using its' on-board dialler to report to the Monitoring Company if unable to make a valid connection using the primary receiver number.

Options:
Any phone number up to 18 digits

Example : *031234567#

Function 04- GSM internal dialler test time Default = 24 (Daily)

Change the time between the SED-62 test call reports (sector 253). The time is in Hour intervals.

0 = No test call reports
24 = Test Call every DAY
168 = Test call once a week

Options:
From 0 to 168 Hours

To force a test call press and hold test button for 7 sec test led will flash , this will send a test call at the time (see Section 2.8)

Example : *0424#
(sets a test call every 24 hours)

Function 05- GSM Fail Relay trigger time Default = 8 minutes

This sets the time between the SED-62 detecting that the GSM signal is not present and when the fault relay activates. This is important for times when the GSM signal can occasionally drop out for short periods but it is not necessary to send an alarm as it restores within a few minutes.

Options:
From 1 to 8 minutes
Example : *055#
(waits 5 minutes before the Fault relay activates)

Function 06- PSTN Alarm delay Default = 1 (30 seconds)

This sets the time between the SED-62 detecting that the PSTN line voltage is low or not present and when a PSTN trouble / fail alarm is reported. This is important in areas where the PSTN line voltage can drop due to loading but the line is still functional and restores normally.

Options:
0 = 50 seconds
1 = 30 seconds
Example : *060#
(50 secs before PSTN Fault activation)

2.5 Function 07- GSM Operation

Default = 1

Sets the way the SED-62 operates as a backup or other modes.

Options:

GSM FT = GSM operates full time (no phone line) _____ 0 = GSM FT= No phone line
GSM BU = GSM operates as a back up unit _____ 1 = GSM BU (default)
GSM FT / PSTN BU = GSM is used full time but will switch _____ 2 = GSM FT / PSTN BU
to PSTN line if the GSM fails. This
requires a dedicated PSTN line

Example : *071#

Function 08- PABX mode

Default = 0

If the Alarm Panel PSTN line is connected through a PABX then the receiver phone number will have an outside line number as a prefix (usually 0). In PABX mode the SED-62 will ignore this first digit when it dials out on the GSM network as it is not required.

Options:

0 = Dial all numbers
1 = Ignore the 1st Digit

Example : *080#

Function 09- Zone 1 – 4 lock out control

Default = 0

This function provides a lockout feature on the 4 SED-62 zone inputs. Enable this to block reporting of rapid multiple activations on a zone input.

Options:

0 = No Lockout
1 = Enter in minutes (1-30)

Example : *091#

Function 10- Ademco event codes

Default = 0

Sets the starting number for the SED-62 onboard dialer reporting codes. In most cases reporting codes 250 and above are OK to use as the alarm panel does not need this many codes but in larger systems where code 250 is in use, the report codes for the SED-62 can be changed to 450 and above. Also Option 2 allows for ademco standard event codes for power fail, low batt, PSTN Fail and GSM Test. Refer to Section 2.10 for a list of report codes and event codes.

Options:

0 = Starting at 250 (default)
1 = Starting at 450
2 = Standard Event Codes

Example : *100#

Function 11- Software Version

Displays the software version of the SED-62 program code. The read-back will be a 2 digit number.

No Options

(Read-back only)

Example : *11#

2.6

Function 12- Mobile phone 1

The SED-62 can report events via SMS to 3 mobile phones (see section 2.8) **Note:** we only recommend this option for non-critical alarms or for secondary monitoring purposes due to the nature of the SMS delivery service. Enter the number of the first mobile phone to report to. If left empty Mobile Phone Reporting is disabled.

Options:

Any phone number
Up to 18 digits

Example : *120406991992#

Function 13- Mobile phone 2

Enter the number of the second mobile phone for the SED-62 to report events to.
Leave this option blank if no second mobile is needed.

Options:

Any phone number
Up to 18 digits

Example : *130406991993#

Function 14- Mobile phone 3

Enter the number of the third mobile phone for the SED-62 to report events to.
Leave this option blank if no third mobile is needed.

Options:

Any phone number
Up to 18 digits

Example : *140406991994#

Function 15- SMS System reporting

Default = 0

This function determines what SMS System Messages are sent by the SED-62. SMS System messages are AC Fail, Low Batt, GSM Test and Fail to Communicate.

Options:

0 = Disable SMS Messages
1 = Enable Option 1
2 = Enable Option 2

Option 1 = Sends All System Messages to Mobiles Option 2 = Send all system Messages except GSM Test
--

Example : *150#

Function 16- SMS Zone reporting

Default = 0

Enable this function if you would like an SMS message sent to the mobile phone number, 1,2,3 if Zones 1- 4 are activated. See Section 2.9 for changing the text of the SMS message.

Options:

0 = Disabled
1 = Enabled

Example : *160#

2.7 Function 17- Zone Input configuration

Default = 0

Sets the operation of the 4 Zone Inputs on the SED-62

Option 0 = Zones 1-4 24 hour inputs
Option 1 = Zones 1-4 armed / disarmed via SMS
Option 2 = Zones 1-3 are 24 Hr but Zone 4 is a control type and switches PSTN over to GSM

Options:

0 = Option 0
1 = Option 1
2 = Option 2

Example : *171#

Function 18- SMS Zone Arming Confirmation

Default = 0

Enables confirmation SMS Message of arm / disarm of Zones 1- 4 (Function 17 = 1) See Section 2.9 for more details

Options:

0 = Disabled
1 = Enabled

Example : *181#

(SMS Confirmation Enabled)

Function 19- Master Code

Default = Nil

If you want to restrict access to the SED-62 programming. Enter a 4 digit PIN number. You will have to then enter *19pin# before you can reprogram or gain access to the SED-62 once set (by either Manual Mode or SMS Programming Mode) Once the *19pin# is entered it will allow you into the programming mode for 5 minutes.

Options:

Any 4 digit number

Example : *191234#

(Sets Master Code to 1234)

Function 24- Fault Relay

Default = 0

Sets the operation of the Fault Relay

Option 0 = relay operates in normal mode
Option 1 = Inverts relay to operate in fail safe mode
Option 2 = Disables relay as fault relay and relay is controlled via SMS as relay 0.
(see Section 2.9 for SMS output control)

Options:

0 = Option 0
1 = Option 1
2 = Option 2

Example : *242#

(Relay controlled by SMS)

Function 25- I/O Expander Board

Default = 0

Enables the I/O expander board option. Only enable this if an I/O expander board has been plugged into the SED-62. Once fitted this provided a additional 4 inputs and 4 outputs

Options:

0 = Disabled
1 = Enabled

Example : *251#

(I/O Expander Board Enabled)

SMS Reports

2.8

NOTE: SMS commands must be as shown. (MUST BE IN CAPITALS)

From any GSM mobile phone, Simply send an SMS text message as shown below to the SED-62 mobile phone number and it will send back an SMS message with the requested report information.

Abc 158
?
Options Back

Available SED-62 SMS reports

- ?P = Request SED-62 program setup
- ?S = Request SED-62 current status
- ?H = Request History - Displays the last 20 events
- ?T= Force test call now to control room

?S

Send a **?S** to request the current status of the SED-62. The current status's for the AC power, PSTN, Battery and GSM Signal Strength will be shown.

**NOTE: If a Master Code has been set in the SED-62, you will not get a response from any command (except for ?S).
See Function 19 for information on the Master Code setup.**

?P

Send a ?P to request the current program function settings. See Section 2.3 for the list of function numbers and options.

?H

Send a ?H to request a list of the last 20 events that have occurred on the SED-62. The first event listed is the oldest .

LEGEND

DT = GSM Dialer test	i1 = input 1	TO=timed out
LB = Low battery	i2 = input 2	PB= program via button
PF = AC Power fail	i3 = input 3	PS= program via sms
SF = GSM signal fail	i4 = input 4	iD=inputs disarmed
LF = PSTN line fail	DF = Dialer fail	iA=inputs armed

?T

When a ?T is sent to the SED-62, it will force a test call to the control room and will reset the Test Call timer to start from this time. This can also be done by holding the test button down for 10 seconds

2.9

SMS Commands

The following SMS commands control additional features of the SED-62.

NOTE: SMS commands must be as shown. (MUST BE IN CAPITALS)

Zone Arm and Disarm feature

The SED-62 Zone Inputs can be armed or disarmed by sending the following SMS Text Message. This command will arm/disarm all Zone Inputs.

Important: It is advisable to program functions 16,17 & 18 to Option 1, and program the mobile numbers into function 12, 13 & 14 if necessary.

Arm / Disarm Commands

?ON = Arms all 4 zones (must be in capitals)

?OFF = Disarms all 4 zones (must be in capitals)

Zone Inputs Individual Text Labels

The SED-62 Zone Inputs can be programmed with individual text labels for SMS reporting.

Text Message Format

In<Input><Text Description>

Parameter Description:

<Input> = Zone Input Number

<Text Description> = Max 10 Characters (including spaces)

Example:

In1front door will program Zone 1 with "front door" (MAX 10 CHAR)

Relay Control

To control the SED-62 Output Relays, send an SMS message as follows:

Text Message Format

Out<Relay>on {Timer}

Out<Relay>off {Timer}

Parameter Description:

<Relay> = Relay Number

{Timer} = Optional timer value in Hours [h] minutes [m] and seconds

Example (for Relay 5)

Out5on = Turns Relay 5 on (indefinitely)

Out5off = Turns Relay 5 off (indefinitely)

Out5on2 = Turns Relay 5 on for 2 seconds (if relay is off)

Out5off2 = Turns relay 5 off for 30 seconds (if relay is on)

Note: Relays 1 - 4 are via an expander board, which must be enabled in programming (see function 25). Relay 5 is onboard as standard and Relay 0 can be enabled if the fault relay is not required (see function 24).

Control Room report codes

2.10

The SED-62 on-board dialler will send Ademco 140 contact ID codes followed by the point number eg 250 This should be treated the same as a sector 250 like any standard alarm panel. eg Tecom Challenger

GSM Dialler Ademco Codes			
Alarm event	Function 10 = 0	Function 10 = 1	Function 10 = 2
SED-62 AC power fail after 1 hr	140 Sector 250	140 Sector 450	301 Sector 250
SED-62 low battery < 10.7v	140 Sector 251	140 Sector 451	302 Sector 251
SED-62 Telecom line fail	140 Sector 252	140 Sector 452	351 Sector 252
SED-62 GSM test	140 Sector 253	140 Sector 453	602 Sector 253
SED-62 Zone Input 1	140 Sector 254	140 Sector 454	140 Sector 254
SED-62 Zone Input 2	140 Sector 255	140 Sector 455	140 Sector 255
SED-62 Zone Input 3	140 Sector 256	140 Sector 456	140 Sector 256
SED-62 Zone Input 4	140 Sector 257	140 Sector 457	140 Sector 257
SED-62 Zone Input 5 (expander)	140 Sector 258	140 Sector 458	140 Sector 258
SED-62 Zone Input 6 (expander)	140 Sector 259	140 Sector 459	140 Sector 259
SED-62 Zone Input 7 (expander)	140 Sector 260	140 Sector 460	140 Sector 260
SED-62 Zone Input 8 (expander)	140 Sector 261	140 Sector 461	140 Sector 261
	DEFAULT		
Note: restores are also sent for each code			

Local domestic dialing

2.11

If you require the SED 62 to call your phone or mobile if any of the system alarms are Activated .You can do this by setting the client code to 0000 and then by putting a Mobile or phone number in Locations 02 , 03

(**Note:** when you do this you will disable the back to base feature)

When there is a GSM system alarm present it will call the phone and then present alternating tones for 15 seconds ,You must wait for the last 3 tones in a row to complete and then either hold down the No 9 key for 7 seconds or whistle to stop, if the SED 62 recognizes your kiss OFF it will give you long single tone , then hang up, if not the unit will call you again for 6 attempts.

3.1 Enabling GPRS

1/ To enable the SED 62 for GPRS you must 1st have a SIM card that has been supplied by Suretek. Phone Suretek on 1300 65 44 33 to obtain your GPRS SIM card.

2/ Suretek will then program the SED 62 remotely for GPRS:

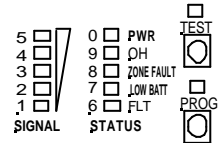

The unit must be powered up and showing signal strength. Suretek (Ph 1300 65 44 33) will then remotely program the SED 62 for GPRS supervise polling.

Once this has been complete and is on line the OH light will flash every 3 seconds to indicate the unit is on line and polling, every 30 seconds the OH led will flash for 5 seconds to poll the base end, it is now GPRS enabled.

3.2 Operational modes in GPRS

You can now operate the SED 62 in either mode 1 or mode 2 for GPRS

MODE 1 : The SED 62 will allow the alarm panel to dial out on the phone line as **normal** but will poll the SED 62 every 90 seconds on GPRS for system integrity.

Any system alarms from the SED 62 will go via GPRS & in the event the Phone Line is severed all alarms from the panel will then go via the GSM voice channel to Contact Id receiver.

MODE 2 : All alarms will be sent via GPRS. The alarm panel will dial out via GPRS thru the SED 62. In the event the GPRS network is not available the alarm will be sent via GSM. If there is no available GSM network signal, it will revert to the phone line if present.

Note: For mode 2 operation, you are required to have a dedicated phone line.

NOTE SEE TESTING GUIDE 4.3

4.1 Testing and Commissioning

Please perform the following tests after completing the installation of the SED-62.

Testing the SED-62 Basic GSM Backup

- 1/ With the SED-62 powered up and working (Status LED flashing and at least 3 bars of signal strength) , disconnect the T-socket from incoming telecom line.
- 2/ The SED-62 will detect a line fault after a short period (Line Fail LED will illuminate) and then, after the PSTN fail detect time 30 sec the fault relay will activate (unless function 24 is not at the default). Also, if the SED-62 is in intelligent mode, a PSTN line fail will be reported to the Alarm Company by the SED-62.
- 3/ Now trigger an alarm on the customers alarm panel. As the alarm panel dials out, it will communicate over the GSM network through the SED-62. On the SED-62 the OH light (LED 9) will come on solid, indicating that the alarm panel is communicating over the GSM network.
- 4/ Once the Alarm Panel has successfully reported the alarm, it will hang up. Check with the Monitoring Company that they received the correct alarm report. If the alarm panel does not communicate successfully check Section 3.2 to diagnose the problem.
- 5/ Once testing is complete, plug the telephone line back in to the T-socket. The line fail LED should go out and after about 1 minute the fault relay will de-activate.

Testing the SED-62 Intelligent GSM Backup

- 1/ Make sure Functions 1, 2 & 3 on the SED-62 are programmed and that the SED-62 is working (Status LED flashing and at least 3 bars of signal strength).
- 2/ Activate then re-seal Zone 1 on the SED-62. The OH light (LED9) will flash while the SED- 62's internal dialler is dialling. The SED-62 will report a Sector 254 to the monitoring company (this should take less than 10 seconds).
- 3/ Disconnect the T-socket from incoming telecom line.
The line fail LED will illuminate and, after about 20 seconds, the OH light (LED 9) will start flashing as the SED-62 reports a Sector 252 to the monitoring Company. Once the OH light stops flashing the fault relay will activate.
- 4/ Now plug the T-socket back into phone line and the SED-62 will send a PSTN restore through.
- 5/ Check with the Monitoring Company that they received the correct alarm reports. (Zone 1 set/restore and PSTN set/restore) If the alarm panel does not communicate successfully check Section 3.2 to diagnose your problem.

4.2

Fault Guide

Before calling for support please look to see if your problem is listed below.

1. The Fault light is on or flashing

Remove the power from the SED-62 then remove the SIM card and put it in a working GSM phone. Turn the GSM phone on. If the phone asks for a PIN number, the SIM card is pin code locked. Go to phone set up / security settings and turn the PIN request off. Power off the phone then on again. It should not ask for a PIN. Put the phone next to the SED-62 antenna location and make sure you have at least 3 bars of signal on the GSM phone. Making sure the power is still off on the SED-62, re-insert the SIM card and power it up. When the SED-62 finds signal, the wake led should be on with the status led flashing and the signal meter will show signal.

2. I cannot program the SED-62

With the SED-62 powered up, put a standard PSTN phone into "Con 1" on the SED-62 board. Press and hold the "Program Button" until LED1 lights up, remove your finger immediately from the button. The "Prog LED" should stay illuminated. First, do a LED Test by pressing the * (Star key) on the phone, LEDs 1,3,5 & 6 should light. Now Press the # (hash key), the LEDs 2,4,7 & 9 should light. If no LEDs light up, check that the phone you are using is set to **Tone (DTMF)** dialling and not pulse (Decadic). If the LEDs do light up, do a read back of function 01 by keying on the phone *01# The LEDs should illuminate in order of the client code. If the unit has not been programmed before, the client code should be 0000. If no LEDs illuminate then the SED-62 may have a Master Code (Function 19) You can now try defaulting the SED-62 (but make sure you know all the program settings before doing this, as you will need to re-program the SED-62 from scratch!) Default the unit by being in program mode and entering *996060# To check if it is defaulted OK, do a read back of function 01 again. LED 0 should flash 4 times indicating an account code of 0000.

3. I do not receive a response via SMS

Check that you have the correct mobile number for the SIM card in the SED-62. If it is correct then the SED-62 may have MASTER CODE (Function 19) set. If you know the Master Code try sending the following SMS *19????# (where ???? = Master Code). If it correct the SED-62 will send back an SMS with "PIN OK" If you see this message then you have 5 minutes to send the SED-62 SMS commands. If you still do not get a response then a technician will probably need to visit the site.

4. The SED-62 on-board dialler is not communicating

Check to see if Functions 01, 02 & 03 are programmed correctly. When you trigger a Zone Input on the SED-62, does the OH light flash? If OH (LED 9) is flashing this is indicating that the on-board dialler is working. If the OH LED is not flashing check that the zones are armed. Put a phone into Con 1 and when the OH LED is flashing, pick up the handset and listen in for comms to the Control Room. If you hear comms check with the Control Room that they are monitoring the correct Contact id codes.

Fault Guide cont..

6. I Programmed the SED-62 OK but the Alarm Panel will not communicate with the Control Room via GSM

To test the GSM communications, plug a standard phone or phone Butt into "Con 1" and pickup the handset (off-hook the Butt) , You should hear dial tone, this is generated by the SED-62. If you do not hear a dial tone then make sure:

- 1/ The SED-62 is powered up
- 2/ You are definitely plugged into "Con 1"
- 3/ The phone you are using is good.

If you do hear dial tone, make a call to the control room using the same number that is programmed into the Alarm Panel / SED-62. If you cannot get through try calling your mobile phone. If your mobile phone rings then the SED-62 is good, so check that the control room number is correct.

If when you called the control room number you heard the Ademco BEEP BEEP, then the control room number and the SED-62 are good and the problem is usually in the way the Alarm Panel dialler communicates.

Firstly, check that the Alarm Panel and the SED-62 are using their respective separate plug power packs. A single plug pack should not be used to power both units, make sure the SED-62 is powered by the plug pack provided by Sec-Eng Systems. Next, with the butt still plugged into "Con 1", unplug the t socket from the phone line , wait for line fail led to activate then , activate an input on the Alarm Panel. Listen in on the call while the Alarm Panel communicates to the Control Room by picking up the butt when the OH (LED 9) is illuminated.

If you can hear the panel get through but the control room won't kiss off (you will hear the Panel retry 2 or more times) then it is probably necessary to adjust the Gain Control on the SED-62. To adjust the gain, locate the pots marked "**to**" and "**from**" in the middle of the SED-62 Board. Turn the "**to**" pot to fully clockwise and trigger an alarm on the alarm panel. If it still does not make a successful report then turn the "**from**" pot to fully anti clockwise and test again. If it is still not communicating then return the "**to**" pot to the middle and adjust the "**from**" pot using the same procedure.

5. The Alarm Panel is working on GSM but Control Room is not receiving the Alarms

Put a telephone or phone butt into "Con 1" and and listen to the Alarm Call by picking up the handset when the OH (LED 9) is On. Do you hear a Kiss off signal after the panel has sent through the Alarm information? If you do but the control room says that they didn't receive the alarm then the number may be re routed. Ask the control room for a non-1300 or another 1300 number to try.

4.3

GPRS Testing MODE 1

BASIC GPRS COMMS

1/ If the OH light is flashing every 3 seconds then rapidly every 40 seconds you are polling on GPRS.

Call Suretek on 1300 65 44 33 to confirm the SED 62 is polling via GPRS.

TESTING ALARMS MODE 1

Trigger a zone on the SED 62 and check that the OH light starts to flash for approximately 5 seconds, this confirms the SED 62 has sent zone alarm via GPRS.

If you now disconnect the T piece socket from the phone line, it should after 30 seconds send a line fail thru via GPRS.

IF you now trigger the customers alarm panel it should send an alarm thru via the normal Contact Id receiver via GSM and not via GPRS.

GPRS Testing MODE 2

BASIC GPRS COMMS

1/ If the OH light is flashing every 3 seconds then rapidly every 40 seconds you are Polling on GPRS.

Call Suretek on 1300 65 44 33 to confirm the SED 62 is polling via GPRS.

TESTING ALARMS mode 2

With GPRS **MODE 2** all alarms are converted to data from Contact ID

With the T socket disconnected from the phone line. Now trigger the customers alarm panel, The OH light will light up and the panel will now dial thru the SED 62. If you plug a butt into Con 1 you will be able to hear the Contact ID conversion as the SED 62 is acting as a Contact ID receiver.

Once converted to GPRS DATA the Oh light will flash to indicate it is sending the captured alarms via GPRS.

Check with your control room as the alarms should have gone thru via GPRS.

NOTES

Tech Support Centre

CONTACT SEC-ENG SYSTEMS FOR TECHNICAL SUPPORT

Phone 02-9524 9952

Mon – Fri 8.30Am to 6.00Pm EST

**FOR ALL GPRS RELATED ISSUES PLEASE CONTACT
SURETEK on 1300 65 44 33**

WWW.SECENG.COM.AU

Sydney, Australia