

## INPUTS

<b>All inputs</b>	Are 10k end of line monitored, with a response time of 300 ms. Alarm triggers SIREN, STROBE and REPORTING (depending on setup).
<b>Inputs 1 to 24</b>	Are armed in the on and partial mode (depending on partial setup) May be programmed to have EXIT and ENTRY or EXIT and HANDOVER delays or may be programmed for 24 HOUR operation.
<b>Tamper</b>	Is a 10k monitored input armed 24 hours with no delay. Alarm triggers Siren, Strobe and Reporting. Indication is by the auxiliary led single flashing.
<b>Panic</b>	Is a 10k monitored input armed 24 hours with no delay. Alarm triggers Siren, Strobe and reporting or, optionally, Silent with no Strobe. Indication is by double flashing auxiliary led.
<b>Fire</b>	Is a 10k monitored input, armed 24 hours. Alarm triggers SIREN and STROBE instantly. Alarm REPORTING occurs after 30 seconds, allowing client to reset if false alarm.
<b>Keyswitch</b>	Is a momentary 10k monitored input active 24 hours. When activated, changes the status of the panel from access to secure (if all sectors are sealed) and vice versa.
<b>16-18VAC</b>	These terminals are for connection to a 16 - 18 vac 1.5 amp transformer (plug pack)

## OUTPUTS

<b>Aux 12V</b>	This 12vdc is for detectors etc. The output is via the INTERNAL fuse. Between 200 and 500mA can be delivered to load depending on other loads, eg. siren, strobe. The onboard regulation is rated at 1.5amps and of this, the battery can take up to 200mA depending on the state of charge. One strobe requires 250mA and each speaker 200mA. The panel itself in alarm with one arming station connected draws 150mA approx.
<b>Batt:</b>	This output is connected to the onboard regulator via a resistor which limits the charge current. Charging voltage is 13.7v.
<b>Int sir:</b>	Output to drive 1 x 8 ohm speaker rated at 10 watts, fused via INTERNAL fuse.
<b>Int bell</b>	Output (timed) to drive DC screamers, fused via internal fuse.
<b>Ext stb:</b>	12vdc output to drive 12vdc strobe, fused via EXTERNAL fuse.
<b>Ext sir:</b>	Output to drive 1 x 8ohm speaker rated at 10 watts, fused via EXTERNAL fuse.
<b>Phone Line socket</b>	This is where the Phone lead, which is supplied with the unit is connected. The Phone lead uses pins 2 & 6 of the line socket for the incoming line in a MODE 40 arrangement. Austel approval No. C89/26B/187

**High Integrity Comms Earth**

This terminal connects to a dual GAS ARRESTOR. This device is the same as used in exchanges and main frames to protect against lightning induced voltages. If this terminal is connected to an earth rod or cold water pipe, the tolerance to high voltage or lightning induced transients is greatly increased. The Telecom input normally has a high tolerance to transients but with this terminal connected the tolerance is even greater.  
Use a heavy conductor for this purpose 40/020 or similar.

**Keypad**

These 4 terminals connect to the Keypads.  
The terminal marked + connects to the terminal marked + on the Keypad.  
The terminal marked **C** (clock) connects to the one marked **C** on the Keypad.  
The terminal marked **D** (data) connects to the one marked **D** on the Keypad.  
The terminal marked - connects to the terminal marked - on the Keypad.

**X9**

This 10 pin connector is located on the left hand edge of the PCB above the sector 1 terminals, and is for connection, via a ribbon cable to the 16 SECTION EXPANDER.

### LEDs on the PCB.

On the pcb there are 3 leds.

**Scan:** This green led indicates that the micro-processor is operating and must always be flickering.

**H3:** This red led indicates that sub-audible is on (The STU has nothing to report).

**H5:** This yellow led will flash when a poll is received or when someone is talking on the phone.

**Expander:** If a 16 SECTION EXPANDER has been installed then the green led on it must be flickering.

### Initialization

To initialize the panel to factory defaults enter program mode and use **Function 90** or power the panel up with any button pressed on the keyboard for 3 seconds.

### On Power up

On power up the unit performs an internal self test of EEPROM. If the EEPROM is found to have been corrupted in some way then the factory defaults will be reloaded.

On power up the unit starts off in OFF mode and the sirens operate for half a second.



## PROGRAM READBACK

With the full range of MCM products there are basically two methods of reading back information that has previously been programmed. The first method allows information that is serial in format to be read sequentially ie. phone numbers, while the second method allows all selections to be seen at once ie. sectors assigned as E/E. These are explained below.

### SEQUENTIAL READBACK

Whilst in **PROGRAM** mode, if an option is entered followed by the **TEST** key then that options setting will be read back using the LEDs on the programmer as follows :

" LED "	" INDICATES DIGIT "
1	1
2	2
3	3
4	4
5	5
6	6
7	7
8	8
Partial	9
On	0
Auxiliary	Pause

#### Example

For this example Function 60 is already programmed as **0199**  
If you wish to check Function 60

Enter the function number **60** followed by the **TEST** key.  
( whilst in program mode )

ON LED will light accompanied by a beep	(digit 0)
Then number <b>1</b> LED accompanied by a beep	(digit 1)
Then <b>PARTIAL</b> LED accompanied by a beep	(digit 9)
Then another beep with <b>PARTIAL</b> LED still lit	(digit 9)
Then beep beep and the <b>PROGRAM</b> LED flashing again (test completed ready for next function).	

### PARALLEL READBACK

**For Functions 31 - 36, 49, 50, 51, 52, 55, 56, 61, 76.**

- When the function number is entered the previously selected sections will flash. If at this point the **Code** button is depressed no changes will be made and the program LED will be flashing again.
- To de-select a section re-enter that section number and the section LED will extinguish.

<b>Control Panel Function List</b>			
<b>Function Number</b>	<b>Function</b>	<b>Defaults</b>	<b>Page No.</b>
<b>00</b>	Master Code holder	218572	<b>6</b>
<b>01</b>	User code 1	1111	<b>6</b>
<b>02-30</b>	User code 2 to User code 30	Nil	<b>6</b>
<b>40</b>	Exit time	60 secs	<b>7</b>
<b>41</b>	Entry time	30 secs	<b>7</b>
<b>42</b>	Siren time	10 mins	<b>7</b>
<b>43</b>	Partial mode isolates	Nil	<b>8</b>
<b>47</b>	Panic silent or audible	Audible	<b>8</b>
<b>49</b>	Exit and Entry sections	Sectors 23 - 24	<b>8</b>
<b>50</b>	Exit and handover sections	Nil	<b>8</b>
<b>51</b>	Partial exit and Entry sectors	Nil	<b>9</b>
<b>52</b>	24 hour inputs	Nil	<b>9</b>
<b>53</b>	16 I/P Expander connected	No	<b>9</b>
<b>54</b>	Disable sirens on first keypress	No	<b>9</b>
<b>55</b>	Silent sections	Nil	<b>10</b>
<b>Communications Functions List.</b>			
<b>60</b>	Account Number / Hard ID	9999	<b>10</b>
<b>71</b>	Report Isolates	Yes	<b>10</b>
<b>74</b>	Duress on / off	Off	<b>11</b>
<b>75</b>	Auto isolation	No	<b>11</b>
<b>Special Functions.</b>			
<b>90</b>	Default to factory (see also Initialization)	N/A	<b>11</b>
<b>99</b>	Technician Code	218067	<b>11</b>

## Function 00 - Master Code

*Default - 218572 ( six digits only )*

### Notes:

The Master code is used to enter and change the user codes only (no system setups may be changed). The Master code may be changed by either the Technician or by the holder of the existing Master code.

### Key Sequence

2 1 8 0 6 7 Code

)

0 0

1 2 3 4 5 6 Code

Off

### Operation

Enter valid technician or master code ( default is 218067 )

Select function 00

Enter new 6 - digit Master code  
( in this example code being entered is 123456 )

Exit from Program mode

## Function 01 - User Code 1

*Default - 1111 ( four digits only )*

### Notes:

- 30 User codes may be programmed into the panel. These user codes are programmed using Function numbers **01** to **30** and all are programmed in exactly the same manner.
- No two User Codes may be the same and if **Keyboard Duress** has been enabled by **Function 74** then no two codes can be within 2 digits of each other. eg. if one code is **1234** then the closest a code can be to it is **1236** or **1232**, or else an error beep will be heard.
- The User codes are used to Arm, Disarm, Isolate Sections and test the system only.
- The User codes may be changed by either the Technician or by the holder of the existing Master code.

### Key Sequence

2 1 8 0 6 7 Code

0 1

1 2 3 4 Code

Off

### Operation

Enter valid technician code (default is 218067 )

Select function 01

Enter new 4 - digit User code  
( in this example code being entered is 1234 )

Exit from Program mode

### Note:

- To delete a User Code from the system select the Function for that User Code, depress the **Isolate** button and then the **Code** button, that code has now been deleted.

## Function 02 - 30 User Codes 2 to 30

*Default - Nil ( four digits only )*

### Notes:

- 30 User codes may be programmed into the panel. These user codes are programmed using Function numbers **01** to **30** and all are programmed in exactly the same manner.
- No two User Codes may be the same and if **Keyboard Duress** has been enabled by **Function 74** then no two codes can be within 2 digits of each other. eg. if one code is **1234** then the closest a code can be to it is **1236** or **1232**, or else an error beep will be heard.
- The User codes are used to Arm, Disarm, Isolate Sections and test the system only.
- The User codes may be changed by either the Technician or by the holder of the existing Master code.

### Key Sequence

2 1 8 0 6 7 Code

0 1

1 2 3 4 Code

Off

### Operation

Enter valid technician code (default is 218067 )

Select function 01

Enter new 4 - digit User code  
( in this example code being entered is 1234 )

Exit from Program mode

### Note:

- To delete a User Code from the system select the Function for that User Code, depress the **Isolate** button and then the **Code** button, that code has now been deleted.

<b>Function 40 - Exit Time</b>		<i>Default - 60 seconds</i>
<b>Options</b>		
<b>0</b> - 0 seconds	<b>5</b> - 50 seconds	
<b>1</b> - 10 seconds	<b>6</b> - 60 seconds	
<b>2</b> - 20 seconds	<b>7</b> - 70 seconds	
<b>3</b> - 30 seconds	<b>8</b> - 80 seconds	
<b>4</b> - 40 seconds	<b>9</b> - 90 seconds	
<b>Key Sequence</b>		<b>Operation</b>
<b>2 1 8 0 6 7 Code</b>		Enter valid Technician code (default 218067)
<b>4 0</b>		Select function number 40
<b>5 Code</b>		Select & store option number ( example shows option 5, i.e. 50 secs being selected ).
<b>Off</b>		Exit Program mode
<b>Function 41 - Entry Time</b>		<i>Default - 30 seconds</i>
<b>Options</b>		
<b>0</b> - 0 seconds	<b>5</b> - 50 seconds	
<b>1</b> - 10 seconds	<b>6</b> - 60 seconds	
<b>2</b> - 20 seconds	<b>7</b> - 70 seconds	
<b>3</b> - 30 seconds	<b>8</b> - 80 seconds	
<b>4</b> - 40 seconds	<b>9</b> - 90 seconds	
<b>Key Sequence</b>		<b>Operation</b>
<b>2 1 8 0 6 7 Code</b>		Enter valid Technician code (default 218067)
<b>4 1</b>		Select function number 41
<b>3 Code</b>		Select & store option number ( example shows option 3, i.e. 30 secs being selected ).
<b>Off</b>		Exit Program mode
<b>Function 42 - Siren Time</b>		<i>Default - 10 minutes</i>
<b>Options</b>		
<b>0</b> - 0 seconds	<b>5</b> - 2 min 40 sec	
<b>1</b> - 10 seconds	<b>6</b> - 5 min	
<b>2</b> - 20 seconds	<b>7</b> - 10 min	
<b>3</b> - 40 seconds	<b>8</b> - 21 min	
<b>4</b> - 80 seconds	<b>9</b> - 42 min	
<b>Notes:</b>		
Siren time applies to internal, external and satellite sirens		
Australian Standard AS 2201 limits the siren to be triggered only once per section unless manually re-armed.		
Noise pollution regulations in most states limit siren time to 10 minutes		
<b>Key Sequence</b>		<b>Operation</b>
<b>2 1 8 0 6 7 Code</b>		Enter valid Technician code (default 218067)
<b>4 2</b>		Select function number 42
<b>5 Code</b>		Select & store option number ( example shows option 5, i.e. 2 mins 40 secs being selected ).
<b>Off</b>		Exit Program mode

**Function 43 - Partial Mode***Default - No sections programmed to be isolated.***Note :**

- Partial Mode sets up a pre - programmed list of sections which are isolated.
- Only Sections 1 - 8 or 1 -24 can be entered in Partial Mode

**Key Sequence**

2 1 8 0 6 7 Code

4 3

0 1

0 4

Code

Off

**Operation**

Enter valid Technician Code (default 218067)

Select Function 43

Section 1 entered

Section 4 entered

Store entry

Exit program mode

**Function 47 - Silent or Audible - Panic***Default - Panic audible***Option**

1 Audible Panic

0 Silent Panic ( no strobe or siren )

**Key Sequence**

2 1 8 0 6 7 Code

4 7

0 Code

Off

**Operation**

Enter valid Technician code (default 218067 )

Select Function 47

Select option 0 or 1

Example shows option 0 selected

which is silent panic

Exit Tech mode

**Function 49 - Exit and Entry Sections in ON Mode***Default - 23 + 24*

Display and change which sections will have exit / entry delay.

**Key Sequence**

2 1 8 0 6 7 Code

4 9

0 1

0 7

Code

Off

**Operation**

Enter valid Technician code (default 218067 )

Select Function 49

(selected sections will flash)

Section 1 has exit / entry

Section 7 has exit / entry

Store this selection

Exit program mode

**Function 50 - Exit and Handover Sections in ON Mode***Default none*

Display and change which sections will have exit / handover delay.

**Key Sequence**

2 1 8 0 6 7 Code

5 0

0 2

0 8

Code

Off

**Operation**

Enter valid Technician code (default 218067 )

Select Function 50

(selected sections will flash)

Section 2 has exit / handover

Section 8 has exit / handover

Store this selection

Exit program mode

## Function 51 - Exit / Entry Sections in **Partial** mode *Default none*

Display and change which sections will have exit / entry delay in Partial mode.

Key Sequence	Operation
2 1 8 0 6 7 Code	Enter valid technician code (default 218067 )
5 1	Select Function 51 (previously selected sections will flash)
0 1	Section 1 has exit / entry, Sector 1 led will flash
0 2	Section 2 has exit / entry, Sector 2 led will flash
0 3	Section 3 has exit / entry, Sector 3 led will flash
0 4	Section 4 has exit / entry, Sector 4 led will flash
Code	Store this selection
Off	Exit program mode

## Function 52 - Sections to operate in 24 Hour mode *Default none*

Display and change which sections will operate as 24 hour inputs.

Key Sequence	Operation
2 1 8 0 6 7 Code	Enter valid technician code (default 218067 )
5 2	Select Function 52 (previously selected sections will flash)
0 6	Section 6 is a 24 hour input
0 7	Section 7 is a 24 hour input
2 3	Section 23 is a 24 hour input
2 4	Section 24 is a 24 hour input
Code	Store this selection
Off	Exit program mode

## Function 53 - Enable 16 Input Expander *Default - Non expanded*

- Option**
- 1 Enable Expander Module
  - 0 Disable Expander Module

Key Sequence	Operation
2 1 8 0 6 7 Code	Enter valid technician code (default 218067 )
5 3	Select Function 53
1 Code	Select option 0 or 1 Example shows option 1 selected which is Expander Module enabled
Off	Exit program mode

## Function 54 - Disable sirens on first keypress *Default - Do not disable*

- Option**
- 1 Disable sirens on first keypress
  - 0 Do not disable sirens

**Note:**

- If function enabled, Then if the sirens are operating when the first number in a code is entered, The sirens will be shut off for 10 seconds, After which they will turn on again.
- This only happens once during an Armed or Disarmed period.

Key Sequence	Operation
2 1 8 0 6 7 Code	Enter Tech code( default 218067 )
5 4	Select Function 54
1 Code	Select option 0 or 1 (example is 1 for disable sirens)
Off	Exit program mode

## Function 55 - Silent Sections

*Default none*

Display and change which sections will operate as silent sections. **i.e. Siren and Strobe.**

### Key Sequence

2 1 8 0 6 7 Code  
5 5

0 6

0 7

2 3

2 4

Code

Off

### Operation

Enter valid technician code (default 218067)

Select Function 55

(previously selected sections will flash)

Section 6 is a 24 hour input

Section 7 is a 24 hour input

Section 23 is a 24 hour input

Section 24 is a 24 hour input

Store this selection

Exit program mode

**Note:** - For functions 31,32,33,34,43,49,50,51,52,55

- When the function number is entered the previously selected sections will flash. If at this point the **Code** button is depressed no changes will be made and the program led will be flashing again.

- To de-select a section re-enter that sections number, The section led will be off.

## Function 60 - Account number/Hard ID

*Default - 9998*

### Notes:

- 4 Digits Limits 0001- 9999

- This function is used to enter the account number for transmission to the Central Station.

- The dialler will not dial if account number or phone number not programmed.

### Key Sequence

2 1 8 0 6 7 Code  
6 0  
6 6 6 6 Code

Off

### Operation

Enter valid technician code (default 218067)

Select function 60

Enter Account number - example  
shows account number 6666 entered

Exit Program mode

## Function 71 - Report Isolated Sections

*Default - Isolate reports*

The control panel will not normally report isolated sections

If enabled the control panel will report isolated sections.

### Option

1 Report Isolated sections

0 Do not report Isolated sections

### Key sequence

2 1 8 0 6 7 Code  
7 1

1

Code

Off

### Operation

Enter valid technician code (default 218067)

Select function

Report isolated sections

Store entry

Exit Program mode

## Function 74 - Keyboard Duress On / Off

*Default - Duress disabled*

### Note:

Keyboard duress may be disabled to prevent accidental duress alarms from private residences. Duress is achieved by adding 1 to the last digit eg. 1234 becomes 1235, 6789 becomes 6780.

### Option

- 1 Duress reports enabled
- 0 Duress reports disabled

### Key sequence

2 1 8 0 6 7 Code  
7 4  
1  
Code  
Off

### Operation

Enter valid technician code (default 218067)  
Select Function  
Duress enabled  
Store entry  
Exit Program mode

## Function 75- Auto-Isolation On/Off *Default - Auto Isolation disabled*

Normally if an attempt to arm the panel with a faulted section (other than an exit/entry section) is made the panel will give an error beep. If this option is enabled then faulted sections will be automatically isolated and will be reported as such.

### Option

- 1 Auto Isolation enabled
- 0 Auto Isolation disabled

### Key sequence

2 1 8 0 6 7 Code  
7 5  
1  
Code  
Off

### Operation

Enter valid technician code (default 218067)  
Select Function  
Auto Isolation enabled  
Store entry  
Exit Program mode

## Function 90 - Default System Parameters

### Notes:

This option is used to default all system setup values and user numbers etc, back to known values. Or power up with a button held for 3 seconds.

### Key Sequence

2 1 8 0 6 7 Code  
9 0 Code  
values

### Operation

Enter valid technician code (default 218067)  
Select Function 90 to reset all options to default

## Function 99 - Technician Code

*Default - 218067 ( six digits only )*

### Notes:

The Technician code is used to set up all functions of the system. Those setups are stored in non - volatile memory - ( the setups not lost during loss of power). Enter Tech code only when system is in **OFF** mode.

### Key Sequence

2 1 8 0 6 7 Code  
9 9  
6 5 6 5 6 5 Code  
Off

### Operation

Enter existing technician code (default is 218067 )  
Select function 99  
Enter new 6 - digit Technician code  
( in this example code being entered is 656565 )  
Exit from Program mode

## Reporting Levels.

The 11 input CONTROL STU with the addition of a "16 input expander module" and software, can be upgraded to a 27 input CONTROL STU.

All inputs as well as panel functions are individually reported using the "SECURITEL SERIAL DATA PROTOCOL."

The CONTROL STU will report-

- alarm
- restore
- isolate
- de-isolate
- outstanding (on a poll stu command)

for each of the 24 inputs as well as alarm / restore for the tamper, fire and panic inputs.

LONG STATUS report-

The tamper, fire and panic inputs as well as keyboard panic, keyboard duress, AC fail and low battery are reported using the standard LONG STATUS report.

- pin 1 not used.
- pin 2 not used.
- pin 3 not used.
- pin 4 not used.
- pin 5 not used.
- pin 6 not used.
- pin 7 indicates whether an input is isolated
- pin 8 indicates the fire input condition.
- pin 9 indicates keyboard panic condition.
- pin 10 indicates panic input condition.
- pin 11 indicates keyboard duress condition.
- pin 12 indicates tamper input condition.
- pin 13 AC Fail.
- pin 14 low battery.
- pin 15 self test.

When the panel is armed with one or more inputs isolated (partial seal), those inputs will be individually reported as such and pin 7 in the long status report will be reported as being in alarm to indicate that one or more inputs have been isolated. Pin 7 will remain outstanding until the panel is turned to the off mode, when it will show a restoral. The de-isolated inputs will be reported individually.

30 user codes can be programmed and reported by the CONTROL STU. These IDs are also reported using the "SECURITEL SERIAL DATA PROTOCOL".

When the STU is polled by the central monitoring agency, the STU will respond with an OPEN or CLOSED message with USER CODE 0 followed by the long status report defined above and will also send via the serial data protocol any outstanding alarms on sectors 1 - 24.

## Other features

- **KEYBOARD Panic** Keyboard Panic is achieved by pressing and holding both the OFF and ON keys together and holding for 2 secs. This is a local as well as back to base alarm.  
Keyboard Panic may be triggered and reported more than once, but only one restoral will be sent when a valid user code is next entered.
- **KEYBOARD DURESS** Keyboard Duress is sent by entering your normal 4 digit code but with the last digit incremented by 1.  
If your code is " 1234 " then enter "1235 ", a duress is sent with no local alarm. A duress restore is sent when the next valid code is entered. If the last digit of your code is " 0 " then enter a " 1 " or if a "9" enter a "0".
- **24 HOUR** Inputs which are configured for 24 hour operation, when alarmed will send a restoral when that input is resealed and a valid user code is entered.
- **MAINS FAIL** Mains fail is automatically detected and reported by the control panel.  
When mains fail is detected the power led on the Command Centre will start giving a single flash and will be beeping. The beeper will stop when any button is depressed. After mains has been off for more than 60 minutes the panel will send a mains fail alarm.  
When mains is restored the led will go steady again and after 30 seconds the panel will send a mains restoral.
- **LOW BATT** Low battery is automatically detected and reported by the panel.  
When low batt is detected the power led on the Command Centre will start giving a double flash. After the battery voltage has been low for 30 seconds the panel will send a low battery report.  
When the battery vottage is restored to normal the led will go steady again and after 30 seconds the panel will send a low battery restoral.  
If low battery occurs during the 60 mins mains fail time, then it takes precedence over the mains fail.

## TABLE OF CONTENTS

<b>1.</b>	<b>Panel Hardware</b> Physical Layout. Inputs. Outputs. Indicators on PCB. Initialization. On Power up.	<b>Page 1</b>	<b>1</b>
<b>2.</b>	<b>Programming Information</b> Entering program mode. Program readback.	<b>Page 3</b>	<b>2</b>
<b>3.</b>	<b>Function Summary</b>	<b>Page 5</b>	<b>3</b>
<b>4.</b>	<b>Control Panel Functions.</b> Functions <b>00</b> to <b>55</b>	<b>Page 6</b>	<b>4</b>
<b>5.</b>	<b>Communications Functions.</b> Functions <b>60</b> to <b>75</b>	<b>Page 10</b>	<b>5</b>
<b>6.</b>	<b>Special Functions.</b> Functions <b>90</b> to <b>99</b>	<b>Page 11</b>	<b>6</b>
<b>7.</b>	<b>Reporting Codes</b> Serial Data Protocol Long format message	<b>Page 12</b>	<b>7</b>
<b>8.</b>	<b>Other Features</b>	<b>Page 13</b>	<b>8</b>

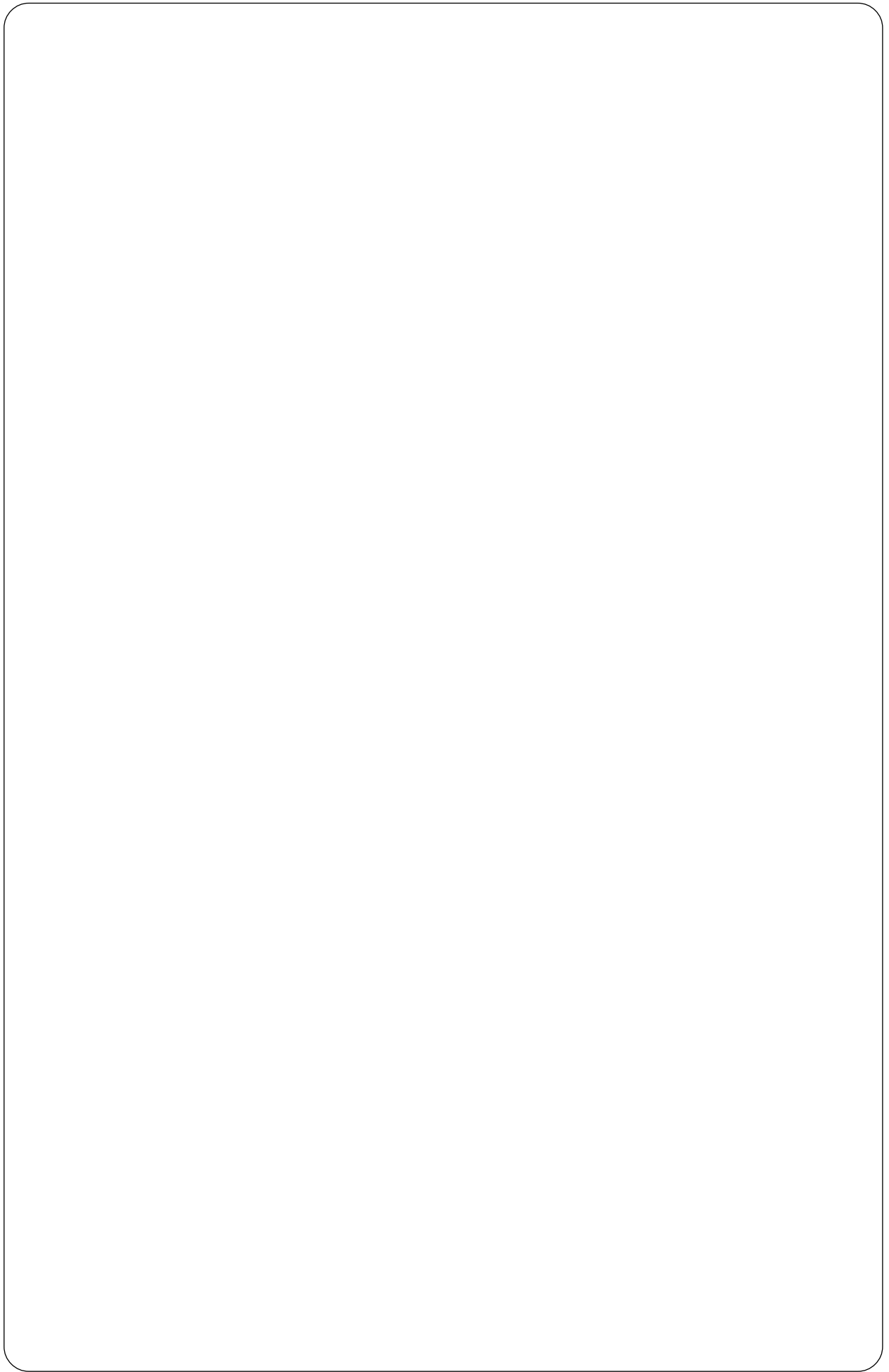

# CSX LAYOUT

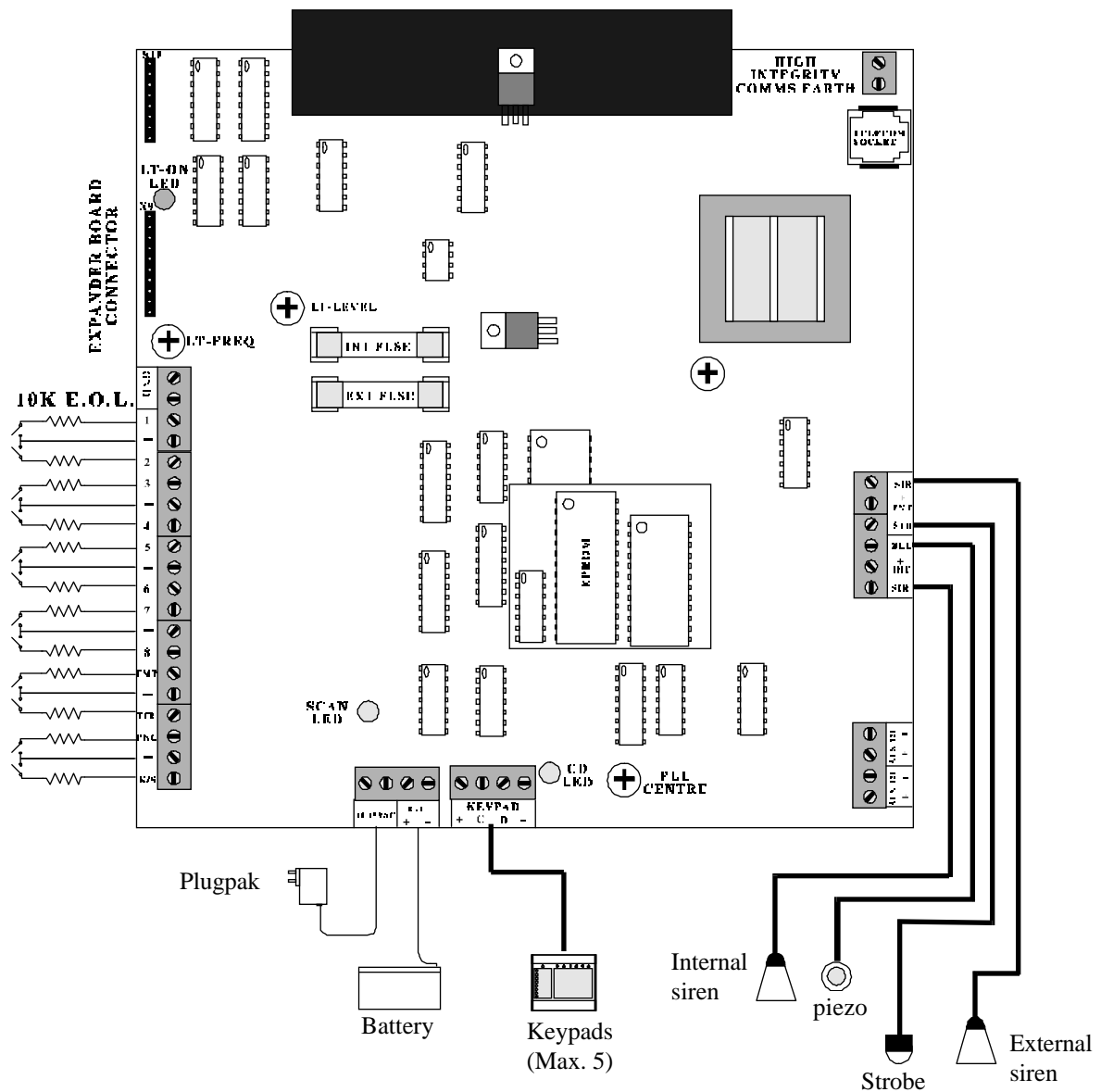

**Note :**

- i. There are no field adjustable controls on the panel.
- ii. The panel can support a maximum of 5 keypads.
- iii. Header X10, located at the top left side of the board, are outputs that can be used for interfacing to external equipment. The pins are open collector outputs and their designations are :
 

X10/1	-	+12vdc via a 10 ohm resistor
X10/2	-	Securitel output - controlled via the Securitel network
X10/3	-	Access/secure output (low = armed)
X10/4	-	Section isolaterd (low = sector is isolated)
X10/5	-	Fire or panic alarm (low = alarm)
X10/6	-	Timed alarm output. follows siren timer (low = alarm)
X10/7	-	Untimed alarm output. Follows strobe output (low = alarm)
X10/8	-	0v

# **CSX8/24**

**Eight sector Securitel Panel  
expandible to 24 sectors**

**Version 5.8**

**Installation and programming manual**

**Proudly Designed and Manufactured  
In Australia by  
MCM ELECTRONICS PTY. LTD.**



**(Incorporated in NSW A.C.N. 003 036 806)  
Unit 3/10 Abel St Penrith NSW 2750 Australia  
P.O. box 6007 South Penrith NSW 2750  
Tel (047) 21 8067 - Fax (047) 21 8572  
International tel. +6147 218067 - Fax: +6147 218572**