

## INPUTS

<b>All inputs</b>	Are 10K end of line monitored, with a response time of 300 ms. Alarm triggers SIREN, STROBE and REPORTING (depending on setup).
<b>Inputs 1 to 24</b>	These inputs may be partitioned into one of the three individually controlled areas or the common area. For more on partitioning see description of Partitioning below. May be programmed to have EXIT and ENTRY or EXIT and HANDOVER delays or may be programmed for 24 HOUR operation.
<b>Fire</b>	Is a 10k monitored input, armed 24 hours. Alarm triggers SIREN and STROBE instantly. Alarm REPORTING occurs after 30 seconds, allowing client to reset if false alarm.
<b>16-18VAC</b>	These terminals are for connection to a 16 - 18 vac 1.5 amp transformer (plug pack)
<b>Partitioning</b>	The 1-24 inputs may be grouped into three independent areas and one common area. The common area is the remaining sections that are not grouped into one of the independent areas. The independent areas can be controlled with both the normal <b>User</b> codes (01-24) and the <b>Super User</b> codes (25-30). The common area is armed when all areas are armed and it is disarmed when any area is disarmed. When a <b>Super User</b> code is entered, control over all the areas is enabled with the exception of not being able to isolate a section of an area that is already armed.

## OUTPUTS

<b>Aux 12V</b>	This 12vdc is for detectors etc. The output is via the INTERNAL fuse. Between 200 and 500mA can be delivered to load depending on other loads, eg. siren, strobe. The onboard regulation is rated at 1.5amps and of this, the battery can take up to 200mA depending on the state of charge. One strobe requires 250mA and each speaker 200mA. The panel itself in alarm with one arming station connected draws 150mA approx.
<b>Batt</b>	This output is connected to the onboard regulator via a resistor which limits the charge current. Charging voltage is 13.7v.
<b>Int sir</b>	Output to drive 1 x 8 ohm speaker rated at 10 watts, fused via INTERNAL fuse.
<b>Int bell</b>	Timed output used to drive DC screamers. Powered via the internal fuse.
<b>Ext stb</b>	12vdc output to drive 12vdc strobe, fused via EXTERNAL fuse.
<b>Ext sir</b>	Output to drive 1 x 8ohm speaker rated at 10 watts, fused via EXTERNAL fuse.
<b>Phone Line socket</b>	This is where the Phone lead, which is supplied with the unit is connected. The Phone lead uses pins 2 & 6 of the line socket for the incoming line in a MODE 40 arrangement. Austel approval No. C89/26B/187

**High Integrity Comms Earth**

This terminal connects to a dual GAS ARRESTOR. This device is the same as used in exchanges and main frames to protect against lightning induced voltages. If this terminal is connected to an earth rod or cold water pipe, the tolerance to high voltage or lightning induced transients is greatly increased. The Telecom input normally has a high tolerance to transients but with this terminal connected the tolerance is even greater.  
Use a heavy conductor for this purpose 40/020 or similar.

**Keypad**

These 4 terminals connect to the Keypad.  
The terminal marked + connects to the terminal marked + on the Keypad.  
The terminal marked C (Clock) connects to the one marked C on the Keypad.  
The terminal marked D (Data) connects to the one marked D on the Keypad.  
The terminal marked - connects to the terminal marked - on the Keypad.

**X9**

This 10 pin connector is located on the left hand edge of the PCB above the sector 1 terminals, and is for connection, via a ribbon cable to the 16 SECTION EXPANDER.

**LEDs on the PCB.**

On the pcb there are 3 leds.

**Scan:**

This green led indicates that the micro-processor is operating and must always be flickering.

**H3:**

This red led indicates that sub-audible is on (The STU has nothing to report).

**H5:**

This yellow led will flash when a poll is received or when someone is talking on the phone.

**Expander:**

If a 16 SECTION EXPANDER has been installed then the green led on it must be flickering.

**Initialization**

To initialize the panel to factory defaults enter program mode and use **Function 90** or power the panel up with any button pressed on the keyboard for 3 seconds.

**On Power up**

On power up the unit performs an internal self test of EEPROM. If the EEPROM is found to have been corrupted in some way then the factory defaults will be reloaded.  
On power up the unit starts off in OFF mode and the sirens operate for half a second.

# ENTERING PROGRAM MODE

There are two codes that will allow access to the MCM product range of panels for programming while the panel is in the access mode. The first is the technicians code that will allow access to all programmable functions and the second is the user master code which allows access only to user code programming. Since the operation of both codes is similar, only the technician code will be discussed.

## DEFAULTING THE PANEL

If the technician and master codes are not known the only way to enter program mode is to default the panel so the factory preset codes may be used. This is accomplished by removing power from the panel and then reapplying power with **ANY** key on the keypad pressed for three seconds. This will restore the factory technician and master codes which are **2 1 8 0 6 7** and **2 1 8 5 7 2** respectively.

**NOTE :** Defaulting the panel will reset **ALL** functions to the factory presets.

## ENTERING PROGRAM MODE

To enter the program mode the following sequence is entered :

**2 1 8 0 6 7 - code** (Enter technician code and press the code key)

At this point the program LED will begin flashing to indicate that you are in program mode and the required function number may be entered. If an error was made in entering the code or an incorrect code used, the keypad will give a long error beep after which you may try again. Assuming we are in program mode the following examples will show how functions are programmed or changed.

### Example 1

To program or change the primary phone number (Function 64) to 02 - pause - 1234567. With the program LED flashing enter the following :

**6 4** (Select Function 64. Program LED will light steady.)  
**0 2** (First two digits of phone number.)  
**partial** (Pressing partial key = 1 second pause.)  
**1 2 3 4 5 6 7** (Remainder of phone number.)  
**code** (Stores phone number. Program LED will begin

flashing.)

At this point the installer can either program further options or leave the program mode by pressing the 'off' key.

### Example 2

Program sectors 1 and 8 to be entry/exit sectors (Function 49). With the programming LED again flashing enter the following :

**4 9** (Select Function 49. Program LED will light steady.)  
**0 1 0 8** (Enter sector numbers 1 (01) and 8 (08).)  
**code** (store information and exit function 49.)  
**off** (Exit program mode. Program LED will extinguish.)

In all cases the **code** key is used as the store key and after it has been pressed the user is returned to the point where the program LED will be flashing again waiting for the next function number. After all programming has been completed the user may exit program mode by pressing the **off** key.

## PROGRAM READBACK

With the full range of MCM products there are basically two methods of reading back information that has previously been programmed. The first method allows information that is serial in format to be read sequentially ie. phone numbers, while the second method allows all selections to be seen at once ie. sectors assigned as E/E. These are explained below.

### SEQUENTIAL READBACK

Whilst in **PROGRAM** mode, if an option is entered followed by the **TEST** key then that options setting will be read back using the LEDs on the programmer as follows :

" LED "	" INDICATES DIGIT "
1	1
2	2
3	3
4	4
5	5
6	6
7	7
8	8
Partial	9
On	0
Auxiliary	Pause

#### Example

For this example Function 60 is already programmed as **0199**  
If you wish to check Function 60

Enter the function number **60** followed by the **TEST** key.  
( whilst in program mode )

ON LED will light accompanied by a beep	(digit 0)
Then number <b>1</b> LED accompanied by a beep	(digit 1)
Then <b>PARTIAL</b> LED accompanied by a beep	(digit 9)
Then another beep with <b>PARTIAL</b> LED still lit	(digit 9)
Then beep beep and the <b>PROGRAM</b> LED flashing again (test completed ready for next function).	

### PARALLEL READBACK

#### For Functions 31 - 36, 49, 50, 51, 52, 55, 56, 61, 76.

- When the function number is entered the previously selected sections will flash. If at this point the **Code** button is depressed no changes will be made and the program LED will be flashing again.
- To de-select a section re-enter that section number and the section LED will extinguish.

<b>Control Panel Function List</b>			
<b>Function Number</b>	<b>Function</b>	<b>Defaults</b>	<b>Page No.</b>
<b>00</b>	Master Code holder	218572	<b>6</b>
<b>01</b>	User code 1	1111	<b>6</b>
<b>02-24</b>	User code 2 to User code 24	Nil	<b>6</b>
<b>25-30</b>	Super User code 25 to Super User code 30	Nil	<b>6</b>
<b>31</b>	Area 1 Sections	Sectors 1 - 8	<b>7</b>
<b>32</b>	Area 2 Sections	Sectors 9 - 16	<b>7</b>
<b>33</b>	Area 3 Sections	Sectors 17 - 22	<b>7</b>
<b>34</b>	Common Area Sections display	Sectors 23 - 24	<b>7</b>
<b>35</b>	User Codes Partitioning	0816	<b>8</b>
<b>40</b>	Exit time	60 secs	<b>8</b>
<b>41</b>	Entry time	30 secs	<b>8</b>
<b>42</b>	Siren time	10 mins	<b>9</b>
<b>47</b>	Panic silent or audible	Audible	<b>9</b>
<b>49</b>	Exit and Entry sections	Sectors 23 - 24	<b>9</b>
<b>50</b>	Exit and handover sections	Nil	<b>10</b>
<b>52</b>	24 hour inputs	Nil	<b>10</b>
<b>53</b>	16 I/P Expander connected	No	<b>10</b>
<b>54</b>	Disable sirens on first keypress	No	<b>10</b>
<b>55</b>	Silent sections	Nil	<b>11</b>
<b>Communications Functions List.</b>			
<b>60</b>	Account Number / Hard ID	9998	<b>11</b>
<b>71</b>	Report Isolates	Yes	<b>11</b>
<b>74</b>	Duress on / off	Off	<b>12</b>
<b>75</b>	Auto isolation	No	<b>12</b>
<b>Special Functions.</b>			
<b>90</b>	Default to factory (see also Initialization)	N/A	<b>12</b>
<b>99</b>	Technician Code	218067	<b>12</b>

## Function 00 - Master Code

*Default - 218572 ( six digits only )*

### Notes:

The Master code is used to enter and change the user codes only (no system setups may be changed). The Master code may be changed by either the Technician or by the holder of the existing Master code.

### Key Sequence

**2 1 8 0 6 7 Code**

**0 0**

**1 2 3 4 5 6 Code**

123456 )

**Off**

### Operation

Enter valid technician or master code

Select function 00

Enter new 6 - digit Master code  
( in this example code being entered is

Exit from Program mode

## Function 01 - 24 User Codes 1 to 24

*Default - 1111 (four digits only)*

### Notes:

- 24 User codes may be programmed into the panel. These user codes are programmed using Function numbers **01 to 24** and all are programmed in exactly the same manner.
- No two User Codes may be the same and if **Keyboard Duress** has been enabled by **Function 74** then no two codes can be within 2 digits of each other eg. if one code is **1234** then the closest a code can be to it is **1236** or **1232** or else an error beep will be heard.
- The User codes are used to Arm, Disarm, Isolate Sections of one area only.
- The User codes may be changed by either the Technician or by the holder of the existing Master code.

### Key Sequence

**2 1 8 0 6 7 Code**

**0 1**

**1 2 3 4 Code**

1234)

**Off**

### Operation

Enter valid technician or master code

Select function 01

Enter new 4 - digit User code  
( in this example code being entered is

Exit from Program mode

### Note:

- To delete a User Code from the system select the Function for that User Code, depress the **Isolate** button and then the **Code** button, that code has now been deleted.

## Function 25 - 30 User Codes 25 to 30 (Super Users)

*Default - Nil*

### Notes:

- 6 SUPER User codes may be programmed into the panel, These user codes are programmed using Function numbers **25 to 30** and all are programmed in exactly the same manner.
- No two User Codes may be the same and if **Keyboard Duress** has been enabled by **Function 74** then no two codes can be within 2 digits of each other eg. if one code is **1234** then the closest a code can be to it is **1236** or **1232**, or else an error beep will be heard.
- The SUPER User codes are used to Arm, Disarm, Isolate Sections and Test all areas.
- The SUPER User codes may be changed by either the Technician or by the holder of the existing Master code.

### Key Sequence

**2 1 8 0 6 7 Code**

**2 5**

**1 2 3 4 Code**

1234)

**Off**

### Operation

Enter valid technician or master code

Select function 25

Enter new 4 - digit User code  
( in this example code being entered is

Exit from Program mode

## Function 31 - Area 1 Sections

*Default 1-8*

Display and change which sections will operate as Area 1 inputs.

### Key Sequence

**2 1 8 0 6 7 Code**  
**3 1**

**0 1**

**0 2**

**0 3**

**Code**

**Off**

### Operation

Enter valid technician code (default 210867 )

Select Function 31

(previously selected sections will flash)

Section 1 is an area 1 input

Section 2 is an area 1 input

Section 3 is an area 1 input

Store this selection

Exit program mode

## Function 32 - Area 2 Sections

*Default 9-16*

Display and change which sections will operate as Area 2 inputs.

### Key Sequence

**2 1 8 0 6 7 Code**  
**3 2**

**0 9**

**1 0**

**1 1**

**Code**

**Off**

### Operation

Enter valid technician code (default 210867 )

Select Function 32

(previously selected sections will flash)

Section 9 is an area 2 input

Section 10 is an area 2 input

Section 11 is an area 2 input

Store this selection

Exit program mode

## Function 33 - Area 3 Sections

*Default 17-22*

Display and change which sections will operate as Area 3 inputs.

### Key Sequence

**2 1 8 0 6 7 Code**  
**3 3**

**1 7**

**1 8**

**1 9**

**Code**

**Off**

### Operation

Enter valid technician code (default 210867 )

Select Function 33

(previously selected sections will flash)

Section 17 is an area 3 input

Section 18 is an area 3 input

Section 19 is an area 3 input

Store this selection

Exit program mode

## Function 34 - Common Area Sections Display

*Default 23,24*

Display which sections which are not in Areas 1,2, or 3 and are therefore are Common Area sections. To change Common Area sections change by using function 31, 32, or 33.

### Key Sequence

**2 1 8 0 6 7 Code**  
**3 4**

**Code**

**Off**

### Operation

Enter valid technician code (default 210867 )

Select Function 34

Common Area Sections are now displayed

Exit this Function

Exit program mode

## Function 35 - User Codes Partitioning

Default 0816

There are two types of user codes that control the three areas. These are the normal USER Codes (01-24) and the SUPER USER Codes (25 - 30). The common area is armed when the last area to be armed is armed and it is disarmed when the first area to be disarmed is disarmed.

The normal USER Codes allow control over only one area, while the SUPER USER Codes allow control over all the areas. To change the number of normal USER Codes allocated to each area, the user code partitions can be changed. This allows each area to have more or less codes than other areas. NOTE: A total of 24 normal User Codes are available for partitioning.

When a SUPER USER code is entered, control over all the areas is enabled with the exception of not being able to isolate a section of an area that is already armed. An area that is already armed will not restart exit delay if a SUPER USER code is used.

### Key Sequence

2 1 8 0 6 7 Code  
3 5  
0 6  
2 0

Code  
Off

### Operation

Enter valid technician code (default 210867)  
Select Function  
Area 1 controlled by user codes 01 - 06  
Area 2 controlled by user codes 07 - 20  
Area 3 controlled by user codes 21 - 24  
Store this selection  
Exit program mode

## Function 40 - Exit Time

Default - 60 seconds

### Options

0 - 0 seconds	5 - 50 seconds
1 - 10 seconds	6 - 60 seconds
2 - 20 seconds	7 - 70 seconds
3 - 30 seconds	8 - 80 seconds
4 - 40 seconds	9 - 90 seconds

### Key Sequence

2 1 8 0 6 7 Code  
  
4 0  
5 Code  
  
Off

### Operation

Enter valid technician code (default 218067)  
  
Select function number 40  
Select & store option number ( example shows option 5, i.e. 50 secs being selected ).  
Exit Program mode

## Function 41 - Entry Time

Default - 30 seconds

### Options

0 - 0 seconds	5 - 50 seconds
1 - 10 seconds	6 - 60 seconds
2 - 20 seconds	7 - 70 seconds
3 - 30 seconds	8 - 80 seconds
4 - 40 seconds	9 - 90 seconds

### Key Sequence

2 1 8 0 6 7 Code  
218067)  
4 1  
3 Code  
  
Off

### Operation

Enter valid technician code (default  
218067)  
Select function number 41  
Select & store option number ( example shows option 3, i.e. 30 secs being selected ).  
Exit Program mode

**Function 42 - Siren Time***Default - 10 minutes***Options**

<b>0</b> - 0 seconds	<b>5</b> - 2 min 40 sec
<b>1</b> - 10 seconds	<b>6</b> - 5 min
<b>2</b> - 20 seconds	<b>7</b> - 10 min
<b>3</b> - 40 seconds	<b>8</b> - 21 min
<b>4</b> - 80 seconds	<b>9</b> - 42 min

**Notes:**

Siren time applies to internal, external and satellite sirens  
 Australian Standards AS 2201 limit siren to be triggered only once per section unless manually re-armed.  
 Noise pollution regulations in most states limit siren time to 10 minutes

**Key Sequence****2 1 8 0 6 7 Code****Operation**

Enter valid technician code (default 218067)

**4 2**

Select function number 42

**5 Code**

Select &amp; store option number ( example shows option 5, i.e. 2 mins 40 secs being

selected ).

**Off**

Exit Program mode

**Function 47 - Silent or Audible - Panic***Default - Panic audible***Option**

<b>1</b> Audible Panic
<b>0</b> Silent Panic ( no strobe or siren )

**Key Sequence****2 1 8 0 6 7 Code****Operation**

Enter valid technician code (default 210867 )

**4 7**

Select Function 47

**0 Code**Select option 0 or 1  
Example shows option 0 selected which is silent panic**Off**

Exit Tech mode

**Function 49 - Exit and Entry Sections***Default - 23 + 24*

Display and change which sections will have exit / entry delay.

**Key Sequence****2 1 8 0 6 7 Code****Operation**

Enter valid technician code (default 210867 )

**4 9**Select Function 49  
(selected sections will flash)**0 1**

Section 1 has exit / entry

**0 7**

Section 7 has exit / entry

**2 3**

Section 23 has exit / entry

**2 4**

Section 24 has exit / entry

**Code**

Store this selection

**Off**

Exit program mode

## Function 50 - Exit and Handover Sections in ON Mode *Default none*

Display and change which sections will have exit / handover delay.

### Key Sequence

2 1 8 0 6 7 Code

5 0

will flash)

0 2

0 8

Code

Off

### Operation

Enter valid technician code (default 210867 )

Select Function 50 (previously selected sections

Section 2 has exit / handover

Section 8 has exit / handover

Store this selection

Exit program mode

## Function 52 - Sections to operate in 24 Hour mode *Default none*

Display and change which sections will operate as 24 hour inputs.

### Key Sequence

2 1 8 0 6 7 Code

5 2

will flash)

0 6

0 7

Code

Off

### Operation

Enter tech code (default 210867 )

Select Function 52 (previously selected sections

Section 6 is a 24 hour input

Section 7 is a 24 hour input

Store this selection

Exit program mode

## Function 53 - Enable 16 Input Expander *Default - Non expanded*

### Option

1 Enable Expander Module

0 Disable Expander Module

### Key Sequence

2 1 8 0 6 7 Code

5 3

1 Code

Off

### Operation

Enter valid technician code (default 210867 )

Select Function 53

Select option 0 or 1

Example shows option 1 selected

which is Expander Module enabled

Exit program mode

## Function 54 - Disable sirens on first keypress *Default - Do not disable*

### Option

1 Disable sirens on first keypress

0 Do not disable siren

### Note:

- If function enabled, then if the sirens are operating when the first number in a code is entered, the sirens will be shut off for 10 seconds, after which they will turn on again.

- This only happens once during an Armed period.

### Key Sequence

2 1 8 0 6 7 Code

5 4

1 Code

Off

### Operation

Enter valid technician code (default 210867 )

Select Function 54

Select option 0 or 1

Example shows option 1 selected

which is disable sirens

Exit program mode

## Function 55 - Silent Sections

*Default none*

Display and change which sections will operate as silent sections. **i.e. Siren and Strobe.**

### Key Sequence

2 1 8 0 6 7 Code  
5 5

0 6

0 7

2 3

2 4

Code

Off

### Operation

Enter valid technician code (default 210867)

Select Function 55

(previously selected sections will flash)

Section 6 is a silent input

Section 7 is a silent input

Section 23 is a silent input

Section 24 is a silent input

Store selections

Exit program mode

**Note:** - For functions 31,32,33,34,43,49,50,51,52,55

- When the function number is entered the previously selected sections will flash. If at this point the **Code** button is depressed no changes will be made and the program led will be flashing again.

- To de-select a section re-enter that section number, the section led will extinguish.

## Function 60 - Account number/Hard ID

*Default - 9998*

### Notes:

- 4 Digits Limits 0001- 9999

- This function is used to enter the account number for transmission to the Central Station.

- The dialler will not dial if account number or phone number not programmed.

### Key Sequence

2 1 8 0 6 7 Code  
6 0  
6 6 6 6 Code

Off

### Operation

Enter valid technician code (default 218067)

Select function 60

Enter Account number - example  
shows account number 6666 entered

Exit Program mode

## Function 71 - Report Isolated Sections

*Default - Isolate reports*

The control panel will not normally report isolated sections

If enabled the control panel will report isolated sections.

### Option

1 Report Isolated sections

0 Do not report Isolated sections

### Key sequence

2 1 8 0 6 7 Code  
7 1

1

Code

Off

### Operation

Enter valid technician code (default 218067)

Select function

Report isolated sections

Store entry

Exit Program mode

## Function 74 - Keyboard Duress On / Off

*Default - Duress disabled*

### Note:

Keyboard duress may be disabled to prevent accidental duress alarms from private residences. Duress is achieved by adding 1 to the last digit eg. 1234 becomes 1235, 6789 becomes 6780.

### Option

- 1 Duress reports enabled
- 0 Duress reports disabled

### Key sequence

2 1 8 0 6 7 Code

7 4

1

Code

Off

### Operation

Enter valid technician code (default 218067)

Select Function

Duress enabled

Store entry

Exit Program mode

## Function 75- Auto-Isolation On/Off

*Default - Auto Isolation disabled*

Normally if an attempt to arm the panel with a faulted section (other than an exit/entry section) is made the panel will give an error beep. If this option is enabled then faulted sections will be automatically isolated and will be reported as such.

### Option

- 1 Auto Isolation enabled
- 0 Auto Isolation disabled

### Key sequence

2 1 8 0 6 7 Code

7 5

1

Code

Off

### Operation

Enter valid technician code (default 218067)

Select Function

Auto Isolation enabled

Store entry

Exit Program mode

## Function 90 - Default System Parameters

### Notes:

This option is used to default all system setup values and user numbers etc, back to known values. Or power up with a button held for 3 seconds.

### Key Sequence

2 1 8 0 6 7 Code

9 0 Code

values

### Operation

Enter valid Technician code (default 218067)

Select Function 90 to reset all options to default

## Function 99 - Technician Code

*Default - 218067 ( six digits only )*

### Notes:

The Technician code is used to set up all functions of the system.

Those setups are stored in non - volatile memory (the setups not lost during loss of power).

Enter Tech code only when system is in **OFF** mode.

### Key Sequence

2 1 8 0 6 7 Code

9 9

6 5 6 5 6 5 Code

Off

### Operation

Enter existing technician code (default 218067 )

Select function 99

Enter new 6 - digit Technician code

( in this example code being entered is 656565 )

Exit from Program mode

## Reporting Levels.

The 8 input partitioned CONTROL STU with the addition of a "16 input expander module" and software, can be upgraded to a 24 input CONTROL STU.

All inputs as well as panel functions are individually reported, using the "SECURITEL SERIAL DATA PROTOCOL."

The CONTROL STU will report-

- alarm
- restore
- isolate
- de-isolate
- outstanding (on a poll stu command)

For each of the 24 inputs as well as individual opening/closing messages for each area.

LONG STATUS report-

The keyboard panic, keyboard duress, AC fail , low battery and input isolated are reported using the standard LONG STATUS report.

- pin 1 not used.
- pin 2 not used.
- pin 3 not used.
- pin 4 not used.
- pin 5 not used.
- pin 6 not used.
- pin 7 indicates whether an input is isolated
- pin 8 not used.
- pin 9 indicates keyboard panic condition.
- pin 10 not used.
- pin 11 indicates keyboard duress condition.
- pin 12 indicates tamper alarm
- pin 13 AC Fail.
- pin 14 low battery.
- pin 15 self test.

When an area is armed with one of more inputs isolated (partial seal), those inputs will be individually reported as such and pin 7 in the long status report will be reported as being in alarm. To indicate that one or more inputs have been isolated, pin 7 will remain outstanding until the all areas with isolated sections are turned to the off mode, when it will show a restoral.

The de-isolated inputs will be reported individually in serial format.

24 normal USER codes and 6 SUPER USER codes can br programmed and reported by the CONTROL STU. These IDs are also reported using the "SECURITEL SERIAL DATA PROTOCOL."

When the STU is polled by the central monitoring agency, the STU will respond with a PARTIAL AREA OPEN or PARTIAL AREA CLOSED message with USER CODE 0 for each of the three areas. If all the areas are armed then the CONTROL STU will also respond with CLOSED USER ID 0. If any area is not armed then the CONTROL STU will respond with OPEN USER ID 0.

## Other features

- **KEYBOARD Panic** Keyboard Panic is achieved by pressing and holding both the OFF and ON keys together and holding for 2 secs. This is a local as well as back to base alarm.
  - Keyboard Panic may be triggered and reported more than once, but only one restoral will be sent when a valid user code is next entered.
  
- **KEYBOARD DURESS** Keyboard Duress is sent by entering your normal 4 digit code but with the last digit incremented by 1.
  - If your code is "1234" then enter "1235", a duress is sent with no local alarm. A duress restore is sent when the next valid code is entered. If the last digit of your code is "0" then enter a "1". Or if a "9" enter a "0".
  
- **24 HOUR:** Inputs which are configured for 24 hour operation, when alarmed will send a restoral when that input is resealed and a valid user code is entered.
  
- **MAINS FAIL:** Mains fail is automatically detected and reported by the control dialler.
  - When mains fail is detected the power led on the Command Centre will start giving a single flash and will be beeping. the beeper will stop when any button is depressed. After mains has been off for more than 10 minutes the dialler will send a mains fail alarm.
  - When mains is restored the led will go steady again and after 30 seconds the dialler will trip and send a mains restoral.
  
- **LOW BATT:** Low battery is automatically detected and reported by the control dialler.
  - When low batt is detected the power led on the Command Centre will start giving a double flash. After the battery voltage has been low for 30 seconds the dialler will send a low battery report.
  - When the battery voltage is restored to normal the led will go steady again after 30 seconds the dialler will send a low battery restoral.
  - If low battery occurs during the 30 second mains fail time, then it takes precedence over the mains fail.

# **CSXP8/24**

**Eight sector Partitionable Securitel Panel  
expandible to 24 sectors**

**Version 8.1**

**Installation and programming manual**

**Proudly Designed and Manufactured  
In Australia by  
MCM ELECTRONICS PTY. LTD.**



**(Incorporated in NSW A.C.N. 003 036 806)  
Unit 3/10 Abel St Penrith NSW 2750 Australia  
P.O. box 6007 South Penrith NSW 2750  
Tel (047) 21 8067, Fax (047) 21 8572**

## TABLE OF CONTENTS

<b>1.</b>	<b>Panel Hardware</b> Physical Layout. Inputs. Outputs. Indicators on PCB. Initialization. On Power up.	Page 1	<b>1</b>
<b>2.</b>	<b>Programming Information</b> Entering program mode. Program readback.	Page 3	<b>2</b>
<b>3.</b>	<b>Function Summary</b>	Page 5	<b>3</b>
<b>4.</b>	<b>Control Panel Functions.</b> Functions <b>00</b> to <b>55</b>	Page 6	<b>4</b>
<b>5.</b>	<b>Communications Functions.</b> Functions <b>60</b> to <b>75</b>	Page 11	<b>5</b>
<b>6.</b>	<b>Special Functions.</b> Functions <b>90</b> to <b>99</b>	Page 12	<b>6</b>
<b>7.</b>	<b>Reporting Codes</b> Serial Data Protocol Long format message	Page 13	<b>7</b>
<b>8.</b>	<b>Other Features</b>	Page 14	<b>8</b>

# CSX LAYOUT

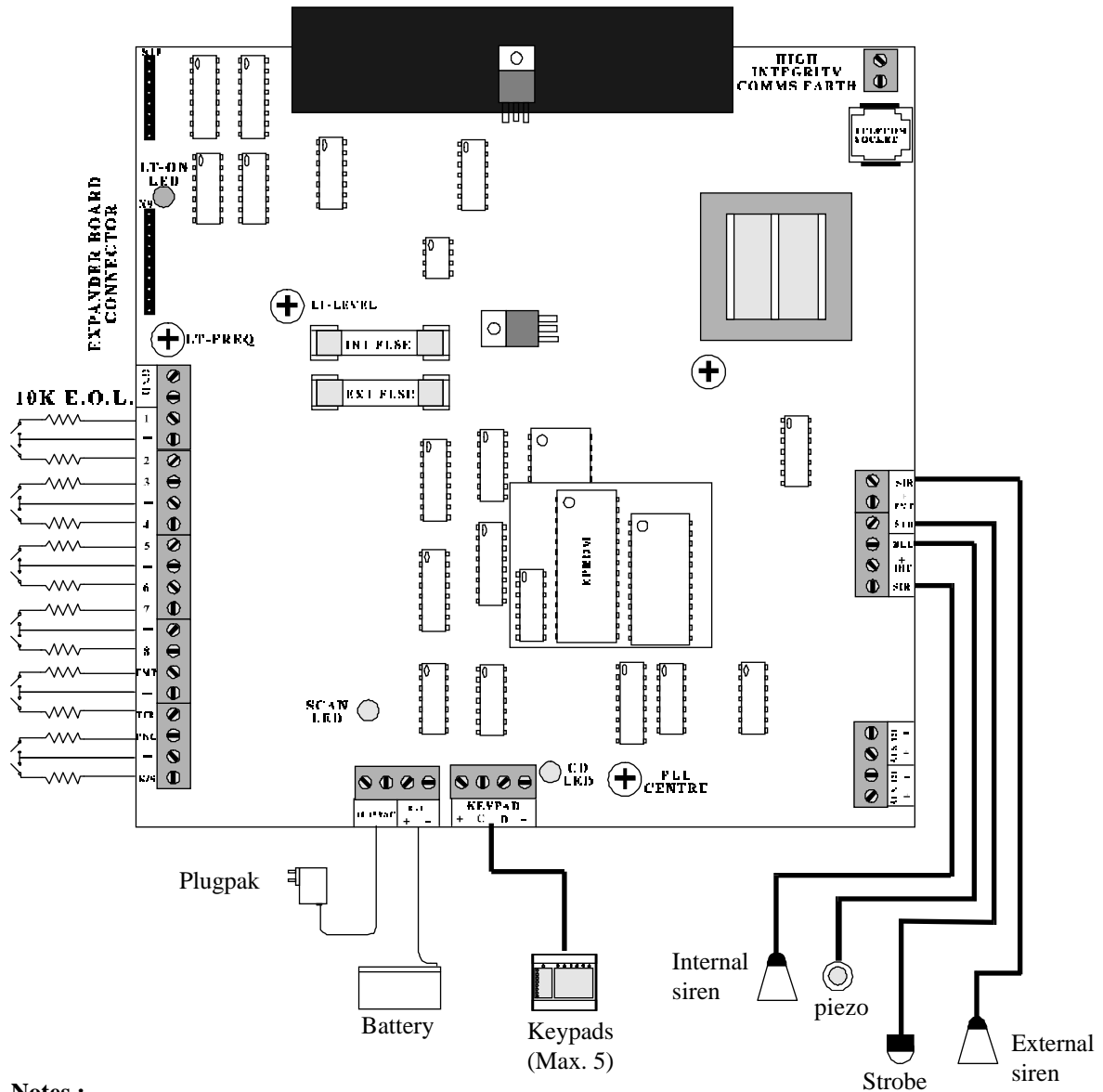

**Notes :**

- i. There are no field adjustable controls on the panel.
- ii. The panel can support a maximum of 5 keypads.
- iii. The fire, panic and keyswitch inputs are not available on the partitioned unit. The tamper input is active and will report and sound the sirens but does not indicate locally.
- iii. Header X10, located at the top left side of the board, are outputs that can be used for interfacing to external equipment. The pins are open collector outputs and their designations are :
 

X10/1	-	+12vdc via a 10 ohm resistor
X10/2	-	Securitel output - controlled via the Securitel network
X10/3	-	Access/secure output (low = armed)
X10/4	-	Section isolated (low = sector is isolated)
X10/5	-	Fire or panic alarm (low = alarm)
X10/6	-	Timed alarm output. follows siren timer (low = alarm)
X10/7	-	Untimed alarm output. Follows strobe output (low = alarm)
X10/8	-	0v